

In-Line Filter

3QF5



Features and Benefits

- Element changeout from the top minimizes oil spillage
- Available with optional core assembly to accommodate coreless elements
- Offered with standard Q, QPML deep-plated and QCLQF coreless elements in 16" and 39" lengths with standard Viton® seals
- Offered in pipe, SAE straight thread, and flange porting
- Integral inlet and outlet test points are standard in all models
- Various Dirt Alarm® options

Model No. of filter in photograph is 3QF539QEDBP40P40.



INDUSTRIAL



AUTOMOTIVE
MANUFACTURING



MACHINE
TOOL



STEEL
MAKING



MINING
TECHNOLOGY



POWER
GENERATION



PULP & PAPER



BULK FUEL
FILTRATION

300 gpm
1135 L/min

500 psi
35 bar

GH

RLT

KF5

SRLT

K9

2K9

3K9

QF5

Viton® is a registered trademark of DuPont Dow Elastomers.

3QF5

Applications

QFD2

QFD5

QF15

QLF15

SSQLF15

Flow Rating: Up to 300 gpm (1135 L/min) for 150 SUS (32 cSt) fluids

Max. Operating Pressure: 500 psi (35 bar)

Min. Yield Pressure: 2500 psi (172 bar), per NFPA T2.6.1

Rated Fatigue Pressure: Contact Factory

Temp. Range: -20°F to 225°F (-29°C to 107°C)

Bypass Setting: Cracking: 30 psi (2.1 bar)
Full Flow: 55 psi (3.8 bar)

Porting Base: Cast Aluminum

Element Case: Steel

Cap: Ductile Iron

Weight of 3QF5: 655 lbs. (298 kg)

Element Change Clearance: 33.8" (859 mm)

Filter Housing Specifications

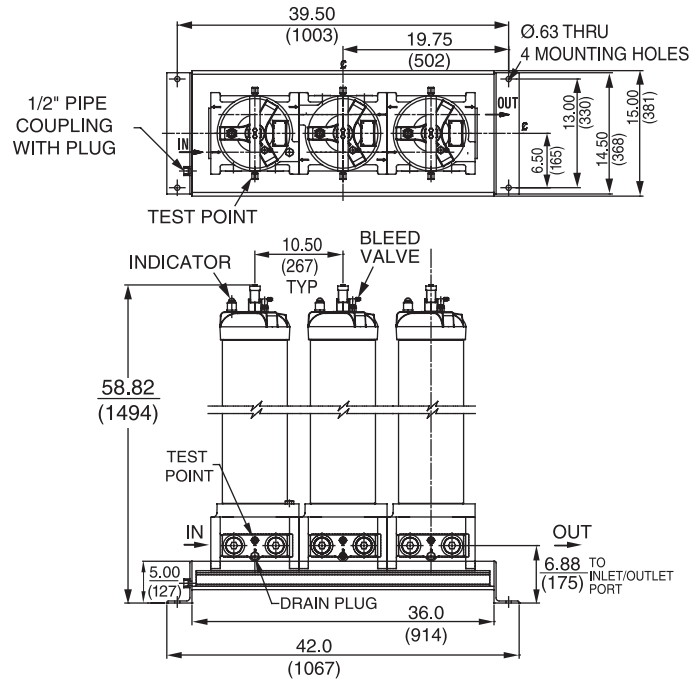

Metric dimensions in ().

Element Performance Information

Element	Filtration Ratio Per ISO 4572/NFPA T3.10.8.8 Using automated particle counter (APC) calibrated per ISO 4402			Filtration Ratio wrt ISO 16889 Using APC calibrated per ISO 11171	
	$\beta_x \geq 75$	$\beta_x \geq 100$	$\beta_x \geq 200$	$\beta_x(c) \geq 200$	$\beta_x(c) \geq 1000$
39Q Z1/CLQFZ1/PMLZ1/	<1.0	<1.0	<1.0	<4.0	4.2
Z3/CLQFZ3/PMLZ3/ AS3V/PMLAS3V	<1.0	<1.0	<2.0	<4.0	4.8
Z5/CLQFZ5/PMLZ5/ AS5V/PMLAS5V	2.5	3.0	4.0	4.8	6.3
Z10/CLQFZ10/PMLZ10/ AS10V/PMLAS10V	7.4	8.2	10.0	8.0	10.0
Z25/CLQFZ25/PMLZ25	18.0	20.0	22.5	19.0	24.0

Dirt Holding Capacity

Element	DHC (gm)	Element	DHC (gm)	Element	DHC (gm)
39Q Z1	974	CLQFZ1	1259	PMLZ1	1485
Z3/AS3V	1001	CLQFZ3	1293	PMLZ3/PMLAS3	1525
Z5/AS5V	954	CLQFZ5	1302	PMLZ5/PMLAS5	1235
Z10/AS10V	940	CLQFZ10	1214	PMLZ10/PMLAS10	1432
Z25	853	CLQFZ25	1102	PMLZ25	1299

Element Collapse Rating: Q and QPML: 150 psid (10 bar), QCLQF: 100 psid (7 bar)

Flow Direction: Outside In

Element Nominal Dimensions: 16Q: 6.0" (150 mm) O.D. x 16.85" (430 mm) long
 16QCLQF: 6.0" (150 mm) O.D. x 18.21" (463 mm) long
 16QPML: 6.0" (150 mm) O.D. x 16.00" (405 mm) long
 39QCLQF: 6.0" (150 mm) O.D. x 40.01" (1016 mm) long
 39QPML: 6.0" (150 mm) O.D. x 37.80" (960 mm) long

Type Fluid Appropriate Schroeder Media

Petroleum Based Fluids	All Z-Media® and ASP media (synthetic)
High Water Content	All Z-Media® and ASP media (synthetic)
Invert Emulsions	10 and 25 µ Z-Media® and 10 µ ASP media (synthetic)
Water Glycols	3, 5, 10 and 25 µ Z-Media® and all ASP media (synthetic)
Phosphate Esters	All Z-Media® (synthetic) with H (EPR) seal designation and all ASP media (synthetic)
Skydrol®	3, 5, 10 and 25 µ Z-Media® (synthetic) with H.5 seal designation (EPR seals and stainless steel wire mesh in element, and light oil coating on housing exterior) and all ASP media (synthetic)

Fluid Compatibility

GH
RLT
KF5
SRLT

Pressure	Series	Element Part No.	Element selections are predicated on the use of 150 SUS (32 cSt) petroleum based fluid and 3" flange porting with a 30 psi (2.1 bar) bypass valve.			
To 500 psi (35 bar)	Z-Media®	16 & 39QZ1	16QZ1	39QZ1		
		16 & 39QZ3	16QZ3			
		16 & 39QZ5	16QZ5			
		16 & 39QZ10	16QZ10			
		16 & 39QZ25	16QZ25 & 39QZ25			
		16 & 39QCLQFZ1	16QCLQFZ1	39QCLQFZ1		
		16 & 39QCLQFZ3	16QCLQFZ3	39QCLQFZ3		
		16 & 39QCLQFZ5	16QCLQFZ5	39QCLQFZ5		
		16 & 39QCLQFZ10	16QCLQFZ10			
		16 & 39QCLQFZ25	16QCLQFZ25			
		16 & 39QPMLZ1	16QPMLZ1	39QPMLZ1		
		16 & 39QPMLZ3	16QPMLZ3	39QPMLZ3		
		16 & 39QPMLZ5	16QPMLZ5	39QPMLZ5		
		16 & 39QPMLZ10	16QPMLZ10			
16 & 39QPMLZ25	16QPMLZ25					
Flow	gpm	0	100	200	300	
	(L/min)	0	500	1000	1135	

Element Selection

Based on Flow Rate

K9
2K9
3K9
QF5
3QF5

Shown above are the elements most commonly used in this housing.

Note: Contact factory regarding use of E media in High Water Content, Invert Emulsion and Water Glycol Applications. For more information, refer to Fluid compatibility: Fire Resistant Fluids, pages 19 and 20.

ΔP_{housing}

3QF5 ΔP_{housing} for fluids with sp gr = 0.86:

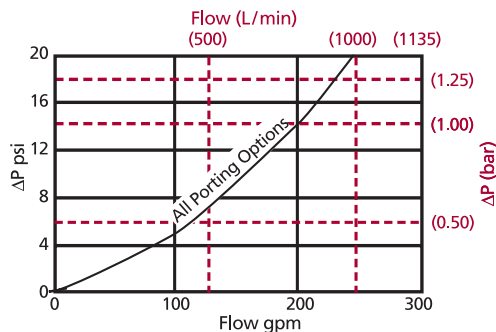

sp gr = specific gravity

Sizing of elements should be based on element flow information provided in the Element Selection chart above.

ΔP_{element}

ΔP_{element} = flow x element ΔP factor x viscosity factor

El. ΔP factors @ 150 SUS (32 cSt):

16QZ1	.09	39QZ1	.03
16QZ3/16QAS3V	.04	39QZ3/39QAS3V	.01
16QZ5/16QAS5V	.04	39QZ5/39QAS5V	.01
16QZ10/16QAS10V	.03	39QZ10/39QAS10V	.01
16QZ25	.01	39QZ25	.01
16QCLQFZ1	.07	39QCLQFZ1	.03
16QCLQFZ3	.05	39QCLQFZ3	.02
16QCLQFZ5	.05	39QCLQFZ5	.02
16QCLQFZ10	.04	39QCLQFZ10	.01
16QCLQFZ25	.03	39QCLQFZ25	.01
16QPMLZ1	.08	39QPMLZ1	.03
16QPMLZ3/		39QPMLZ3/	
16QPMLAS3V	.05	39QPMLAS3V	.02
16QPMLZ5/		39QPMLZ5/	
16QPMLAS5V	.05	39QPMLAS5V	.02
16QPMLZ10/		39QPMLZ10/	
16QPMLAS10V	.04	39QPMLAS10V	.01
16QPMLZ25	.02	39QPMLZ25	.01

If working in units of bars & L/min, divide above factor by 54.9.

Viscosity factor: Divide viscosity by 150 SUS (32 cSt).

Pressure Drop Information

Based on Flow Rate and Viscosity

QF15
QLF15
SSQLF15

$$\Delta P_{\text{filter}} = \Delta P_{\text{housing}} + \Delta P_{\text{element}}$$

Determine ΔP at 150 gpm (570 L/min) for 3QF516QZ3F40D5 using 200 SUS (44 cSt) fluid.

Solution:

$$\Delta P_{\text{housing}} = 9.5 \text{ psi } [.67 \text{ bar}]$$

$$\Delta P_{\text{element1}} = 150 \times .01 \times (200 \div 150) = 2.0 \text{ psi or } [570 \times (.01 \div 54.9) \times (44 \div 32) = .14 \text{ bar}]$$

$$\Delta P_{\text{element2}} = 150 \times .03 \times (200 \div 150) = 6.0 \text{ psi or } [570 \times (.03 \div 54.9) \times (44 \div 32) = .42 \text{ bar}]$$

$$\Delta P_{\text{element3}} = 150 \times .04 \times (200 \div 150) = 8.0 \text{ psi or } [570 \times (.04 \div 54.9) \times (44 \div 32) = .56 \text{ bar}]$$

$$\Delta P_{\text{total}} = 9.5 + 2.0 + 6.0 + 8.0 = 25.5 \text{ psi or } [.67 + .14 + .42 + .56 = 1.79 \text{ bar}]$$

Filter Model Number Selection

How to Build a Valid Model Number for a Schroeder 3QF5:

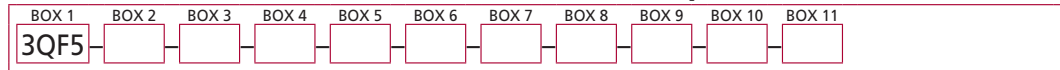

Example: NOTE: One option per box

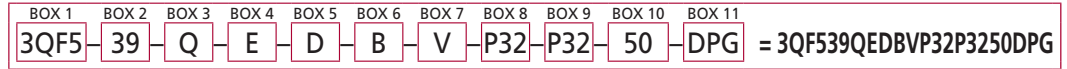

Element Performance Information

BOX 1	BOX 2	BOX 3	BOX 4	BOX 5	BOX 6	BOX 7
Filter Series	Element Length (in)	Element Style	First Housing Element Media	Second Housing Element Media	Third Housing Element Media	Housing Seal Material
3QF5	16 39	Q QCLQF QPML	A = Z1 B = Z3 C = Z5 D = Z10 E = Z25 F = W G = AS3 H = AS5 J = AS10	A = Z1 B = Z3 C = Z5 D = Z10 E = Z25 F = W G = AS3 H = AS5 J = AS10	A = Z1 B = Z3 C = Z5 D = Z10 E = Z25 F = W G = AS3 H = AS5 J = AS10	Omit = Buna N H = EPR V = Viton®

Dirt Holding Capacity

BOX 8	BOX 9	BOX 10
"IN" Porting	"OUT" Porting	Bypass Setting
P24 = 1½" NPTF P32 = 2" NPTF P40 = 2½" NPTF P48 = 3" NPTF S32 = SAE-32 F32 = 2" SAE 4-bolt flange Code 61 F40 = 2½" SAE 4-bolt flange Code 61 F48 = 3" SAE 4-bolt flange Code 61	P24 = 1½" NPTF P32 = 2" NPTF P40 = 2½" NPTF P48 = 3" NPTF S32 = SAE-32 F32 = 2" SAE 4-bolt flange Code 61 F40 = 2½" SAE 4-bolt flange Code 61 F48 = 3" SAE 4-bolt flange Code 61	Omit = 30 psi cracking 50 = 50 psi cracking X = Blocked bypass

BOX 11	
Dirt Alarm® Options	
	Omit = None
Visual	DPG = Standard differential pressure gauge D5 = Visual pop-up D5C = D5 in cap D5R = D5 mounted opposite standard location
Visual with Thermal Lockout	D8 = Visual w/ thermal lockout D8C = D8 in cap D8R = D8 mounted opposite standard location
Electrical	MS5 = Electrical w/ 12 in. 18 gauge 4-conductor cable MS5LC = Low current MS5 MS10 = Electrical w/ DIN connector (male end only) MS10LC = Low current MS10 MS11 = Electrical w/ 12 ft. 4-conductor wire MS12 = Electrical w/ 5 pin Brad Harrison connector (male end only) MS12LC = Low current MS12 MS16 = Electrical w/ weather-packed sealed connector MS16LC = Low current MS16 MS17LC = Electrical w/ 4 pin Brad Harrison male connector
Electrical with Thermal Lockout	MS5T = MS5 (see above) w/ thermal lockout MS5LCT = Low current MS5T MS10T = MS10 (see above) w/ thermal lockout MS10LCT = Low current MS10T MS12T = MS12 (see above) w/ thermal lockout MS12LCT = Low current MS12T MS16T = MS16 (see above) w/ thermal lockout MS16LCT = Low current MS16T MS17LCT = Low current MS17T
Electrical Visual	MS13 = Supplied w/ threaded connector & light MS14 = Supplied w/ 5 pin Brad Harrison connector & light (male end)
Electrical Visual with Thermal Lockout	MS13DCT = MS13 (see above), direct current, w/ thermal lockout MS13DCLCT = Low current MS13DCT MS14DCT = MS14 (see above), direct current, w/ thermal lockout MS14DCLCT = Low current MS14DCT

NOTES:

Box 2. Replacement element part numbers are a combination of Boxes 2, 3, and 4, plus the letter V.
Example: 39QZ10V

Box 3. QCLQF are CoreCentric® coreless elements – housing includes rigid metal core. QPML are deep-pleated elements with more media and higher dirt holding capacity.

Box 4. For option F, Box 3 must equal Q.

Box 7. All elements for this filter are supplied with Viton® seals. Seal designation in Box 5 applies to housing only. Viton® is a registered trademark of DuPont Dow Elastomers.