

Tank-Mounted Filter

BFT



Features and Benefits

- Low pressure tank-mounted filter
- Designed for high return line flows
- Dual inlet porting
- Top, side or bottom mounting
- Optional check valve prevents reservoir siphoning
- Special filter element design provides aftermarket benefits
- Also available with DirtCatcher® element (BBD)

Model No. of filter in photograph is BFT1BBZ5F.



INDUSTRIAL



MOBILE
VEHICLES



PULP & PAPER



STEEL
MAKING



CONSTRUCTION



AGRICULTURE

300 gpm
1135 L/min
100 psi
7 bar

IRF
TF1
KF3
KL3
LF1-2"
MLF1
RLD
GRTB
MTA
MTB
ZT

Applications

KFT
RT
RTI
LRT
ART
BFT
QT
KTK
LTK
MRT

Filter Housing Specifications

Accessories
for Tank-
Mounted
Filters

Flow Rating:	Up to 300 gpm (1135 L/min) for 150 SUS (32 cSt) fluids
Max. Operating Pressure:	100 psi (7 bar)
Min. Yield Pressure:	250 psi (17 bar), per NFPA T2.6.1
Rated Fatigue Pressure:	Contact factory, per NFPA T2.6.1
Temp. Range:	-20°F to 225°F (-29°C to 107°C)
Bypass Setting:	Cracking: 25 psi (1.7 bar) Full Flow: 52 psi (3.6 bar)
Porting Head & Cap:	Aluminum
Element Case:	Steel
Weight of BFT-1BB:	36.7 lbs. (16.6 kg)
Element Change Clearance:	14.75" (375 mm)

PAF1
MAF1
MF2

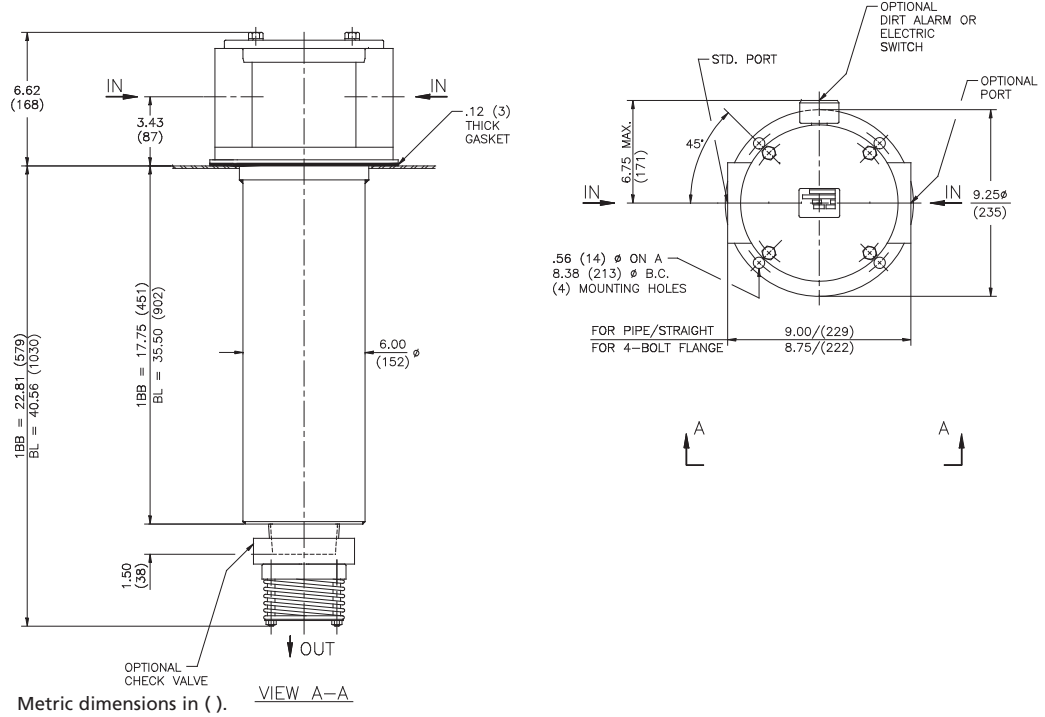

Element Performance Information

Element	Filtration Ratio Per ISO 4572/NFPA T3.10.8.8 Using automated particle counter (APC) calibrated per ISO 4402			Filtration Ratio wrt ISO 16889 Using APC calibrated per ISO 11171	
	$\beta_x \geq 75$	$\beta_x \geq 100$	$\beta_x \geq 200$	$\beta_x(c) \geq 200$	$\beta_x(c) \geq 1000$
BB/BL10	15.5	16.2	18.0	N/A	N/A
BB/BLZ1	<1.0	<1.0	<1.0	<4.0	4.2
BB/BLZ3	<1.0	<1.0	<2.0	<4.0	4.8
BB/BLZ5	2.5	3.0	4.0	4.8	6.3
BB/BLZ10	7.4	8.2	10.0	8.0	10.0
BB/BLZ25	18.0	20.0	22.5	19.0	24.0

Dirt Holding Capacity

Element	DHC (gm)	Element	DHC (gm)	Element	DHC (gm)
BB10	132	BL10	264		
BBZ1	268	BBDZ1	205	BLZ1	536
BBZ3	275	BBDZ3	163	BLZ3	550
BBZ5	301	BBDZ5	229	BLZ5	550
BBZ10	272	BBDZ10	183	BLZ10	550
BBZ25	246	BBDZ25	186	BLZ25	550

Element Collapse Rating: 150 psid (10 bar)

Flow Direction: Outside In

Element Nominal Dimensions: BB: 5.0" (125 mm) O.D. x 18.0" (460 mm) long
BL: 5.0" (125 mm) O.D. x 36.0" (920 mm) long

Tank-Mounted Filter

BFT

Type Fluid	Appropriate Schroeder Media
Petroleum Based Fluids	All E media (cellulose) and Z-Media® (synthetic)
High Water Content	All Z-Media® (synthetic)
Invert Emulsions	10 and 25 µ Z-Media® (synthetic)
Water Glycols	3, 5, 10 and 25 µ Z-Media® (synthetic)
Phosphate Esters	All Z-Media® (synthetic) with H (EPR) seal designation
Skydrol®	3, 5, 10 and 25 µ Z-Media® (synthetic) with H.5 seal designation (EPR seals and stainless steel wire mesh in element, and light oil coating on housing exterior)

Fluid Compatibility

IRF
TF1
KF3
KL3
LF1-2"

Skydrol® is a registered trademark of Solutia Inc.

Pressure	Element		Element selections are predicated on the use of 150 SUS (32 cSt) petroleum based fluid and a 25 psi (1.7 bar) bypass valve (with check valve option).				
	Series	Part No.					
Return Line Tank-Mounted	E Media	BB10	BB10				
		BB25	BB25				
	Z-Media®	BBZ/BLZ1	BBZ1*		BLZ1		
		BBZ/BLZ3	BBZ3*		BLZ3		
		BBZ/BLZ5	BBZ5 / BLZ5				
		BBZ/BLZ10	BBZ10 / BLZ10				
BBZ/BLZ25	BBZ25 / BLZ25						
Flow	gpm	0	100	150	200	250	300
	(L/min)	0	400	600	800	1000	1150

Element Selection Based on Flow Rate

MLF1
RLD
GRTB
MTA
MTB
ZT

Shown above are the elements most commonly used in this housing.

*Note: Additional per element flow is available up to 300 gpm when using BFT filter without check valve option. See housing pressure drop graph below.

Note: Contact factory regarding use of E Media in High Water Content, Invert Emulsion and Water Glycol Applications. For more information, refer to Fluid Compatibility: Fire Resistant Fluids, pages 19 and 20.

ΔP_{housing}

BFT ΔP_{housing} for fluids with sp gr = 0.86:

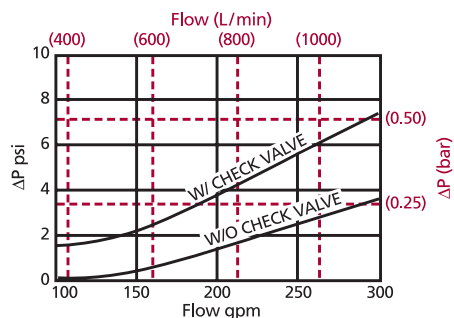

sp gr = specific gravity

Sizing of elements should be based on element flow information provided in the Element Selection chart above.

ΔP_{element}

ΔP_{element} = flow x element ΔP factor x viscosity factor

El. ΔP factors @ 150 SUS (32 cSt):

	BB	BL	BBD	
BB10	.03	.01		
BB25	.01	.01		
BBZ1	.07	.04	BBZ1	.08
BBZ3	.05	.03	BBZ3	.06
BBZ5	.04	.02	BBZ5	.05
BBZ10	.03	.02	BBZ10	.04
BBZ25	.02	.01	BBZ25	.02

If working in units of bars & L/min, divide above factor by 54.9.

Viscosity factor: Divide viscosity by 150 SUS (32 cSt).

Pressure Drop Information Based on Flow Rate and Viscosity

RTI
LRT
ART
BFT
QT
KTK
LTK
MRT

Notes

$$\Delta P_{\text{filter}} = \Delta P_{\text{housing}} + \Delta P_{\text{element}}$$

Exercise:

Determine ΔP at 160 gpm (600 L/min) for BFT1BBZ3PCY2 using 200 SUS (44 cSt) fluid.

Solution:

$$\begin{aligned} \Delta P_{\text{housing}} &= 2.5 \text{ psi } [.20 \text{ bar}] \\ \Delta P_{\text{element}} &= 160 \times .05 \times (200 \div 150) = 10.7 \text{ psi} \\ &\text{or} \\ &= [600 \times (.05 \div 54.9) \times (44 \div 32) = .8 \text{ bar}] \\ \Delta P_{\text{total}} &= 2.5 + 10.7 = 13.2 \text{ psi} \\ &\text{or} \\ &= [.20 + .8 = 1.0 \text{ bar}] \end{aligned}$$

Accessories for Tank-Mounted Filters

PAF1
MAF1
MF2

Filter Model Number Selection

How to Build a Valid Model Number for a Schroeder KF3:

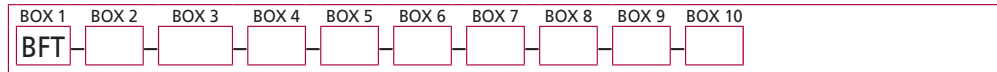

Example: NOTE: Only box 10 may contain more than one option

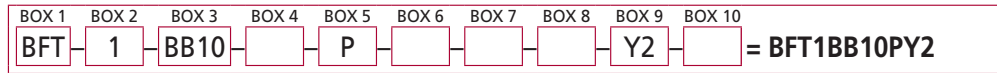

BOX 1	BOX 2	BOX 3			BOX 4
Filter Series	Number of Elements	Element Size and Media			Seal Material
BFT	1	BB Length	BL Length		Omit = Buna N H = EPR W = Buna N H.5 = Skydrol® compatibility
		BB3		= 10 μ E media (cellulose)	
		BB10		= 10 μ E media (cellulose)	
		BB25		= 25 μ E media (cellulose)	
		BBZ1	BLZ1	= 1 μ Excellement® Z-Media® (synthetic)	
		BBZ3	BLZ3	= 3 μ Excellement® Z-Media® (synthetic)	
		BBZ5	BLZ5	= 5 μ Excellement® Z-Media® (synthetic)	
		BBZ10	BLZ10	= 10 μ Excellement® Z-Media® (synthetic)	
		BBZ25	BLZ25	= 25 μ Excellement® Z-Media® (synthetic)	
		BBDZ1		= BB size DirtCatcher® 1 μ Excellement® Z-Media®	
		BBDZ3		= BB size DirtCatcher® 3 μ Excellement® Z-Media®	
		BBDZ5		= BB size DirtCatcher® 5 μ Excellement® Z-Media®	
		BBDZ10		= BB size DirtCatcher® 10 μ Excellement® Z-Media®	
		BBDZ25		= BB size DirtCatcher® 25 μ Excellement® Z-Media®	

BOX 5	BOX 6	BOX 7
Porting	Bypass Setting	Outlet Porting
P = 2½" NPTF PP = Dual 2½" NPTF S = SAE-32 SS = Dual SAE-32 F = 2½" SAE 4-bolt flange Code 61 FF = Dual 2½" SAE 4-bolt flange Code 61	Omit = 25 psi cracking 40 = 40 psi cracking	Omit = 3" NPT male T = 13" Tube extension
	BOX 8	
	Optional Check Valve	
	Omit = None C = Check valve	

BOX 9	BOX 10
Dirt Alarm® Options	Additional Options
Omit = None	Omit = None
Visual Y2 = Back-mounted tri-color gauge Y2R = Back-mounted gauge mounted on opposite side of standard location	G547 = Two ½" gauge ports G1476 = Three-terminal electric switch
Electrical ES = Electric switch ESR = Electric switch mounted on opposite side of standard location ES1 = Heavy-duty electric switch with conduit connector ES1R = Heavy-duty electric switch with conduit connector mounted on opposite side of standard location	M = Metric thread for SAE 4-bolt flange mounting holes (specify after each F port designation)

NOTES:

Box 3. Replacement element part numbers are identical to contents of Boxes 3 and 4. E media elements are only available with Buna N seals.

Box 4. For options H, W, and H.5 all aluminum parts are anodized. H.5 seal designation includes the following: EPR seals, stainless steel wire mesh on elements, and light oil coating on housing exterior. Skydrol® is a registered trademark of Solutia Inc.

Box 8. See also "Accessories for Tank-Mounted Filters," page 295.