

# Top-Ported Pressure Filter

## CF60



### Features and Benefits

- Top-ported high pressure filter
- Available with non-bypass option with high collapse element
- Offered in pipe, SAE straight thread, flange and ISO 228 porting
- No-Element indicator option available

Model No. of filter in photograph is CF601CCZ3SD5.



INDUSTRIAL



AUTOMOTIVE  
MANUFACTURING



MACHINE  
TOOL



MINING  
TECHNOLOGY



STEEL  
MAKING



PULP & PAPER



AGRICULTURE



MOBILE  
VEHICLES

50 gpm  
**190 L/min**  
6000 psi  
**415 bar**

NF30  
NFS30  
YF30  
CFX30  
PLD  
DF40  
CF40  
PF40  
RFS50  
RF60  
**CF60**

### Applications

CTF60  
VF60  
LW60  
KF30  
TF50  
KF50  
KC50  
MKF50  
KC65  
NOF30-05  
NOF50-760  
FOF60-03

### Filter Housing Specifications

NMF30  
RMF60  
Cartridge Elements  
HS60  
MHS60  
KFH50

Flow Rating:	Up to 50 gpm (190 L/min) for 150 SUS (32 cSt) fluids
Max. Operating Pressure:	6000 psi (415 bar)
Min. Yield Pressure:	15,500 psi (1070 bar), per NFPA T2.6.1
Rated Fatigue Pressure:	4000 psi (276 bar), per NFPA T2.6.1-R1-2005
Temp. Range:	-20°F to 225°F (-29°C to 107°C)
Bypass Setting:	Cracking: 40 psi (2.8 bar) Full Flow: 75 psi (5.2 bar) Non-bypassing model has a blocked bypass.
Porting Head:	Ductile Iron
Element Case:	Steel
Weight of CF60-9C:	24.0 lbs. (10.9 kg)
Element Change Clearance:	4.0" (103 mm)

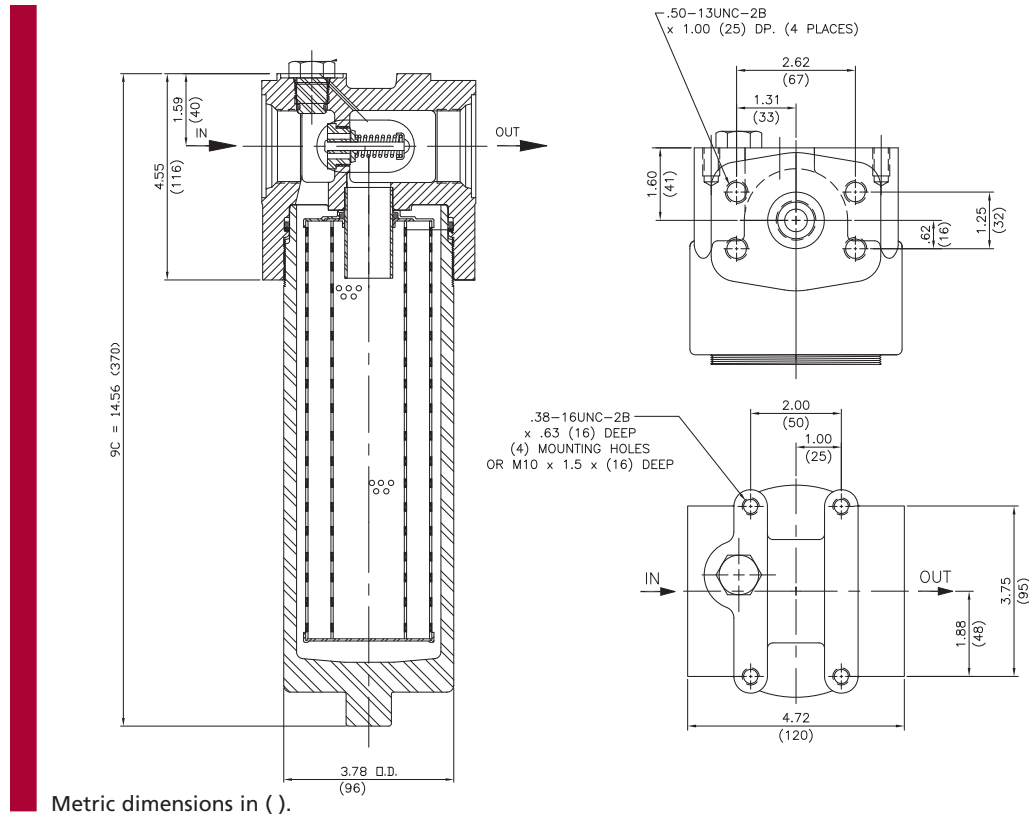

## Element Performance Information

Element	Filtration Ratio Per ISO 4572/NFPA T3.10.8.8 Using automated particle counter (APC) calibrated per ISO 4402			Filtration Ratio wrt ISO 16889 Using APC calibrated per ISO 11171	
	$\beta_x \geq 75$	$\beta_x \geq 100$	$\beta_x \geq 200$	$\beta_x(c) \geq 200$	$\beta_x(c) \geq 1000$
CC3	6.8	7.5	10.0	N/A	N/A
CC10	15.5	16.2	18.0	N/A	N/A
CCZ1	<1.0	<1.0	<1.0	<4.0	4.2
CCZ3/CAS3/CCAS3	<1.0	<1.0	<2.0	<4.0	4.8
CCZ5/CAS5/CCAS5	2.5	3.0	4.0	4.8	6.3
CCZ10/CAS10/CCAS10	7.4	8.2	10.0	8.0	10.0
CCZ25	18.0	20.0	22.5	19.0	24.0
CCZX3	<1.0	<1.0	<2.0	4.7	5.8

## Dirt Holding Capacity

Element	DHC (gm)
CC3	30
CC10	25
CCZ1	57
CCZ3/CAS3/CCAS3	58
CCZ5/CAS5/CCAS5	63
CCZ10/CAS10/CCAS10	62
CCZ25	63
CCZX3	26*

Element Collapse Rating: 150 psid (10 bar) for standard elements  
3000 psid (210 bar) for high collapse (ZX) versions

\*Based on 100 psi terminal pressure

Flow Direction: Outside In

Element Nominal Dimensions: CC: 3.0" (75 mm) O.D. x 9.5" (240 mm) long

# Top-Ported Pressure Filter

# CF60

Type Fluid	Appropriate Schroeder Media
Petroleum Based Fluids	All E media (cellulose), Z-Media® and ASP Media (synthetic)
High Water Content	All Z-Media® and ASP Media (synthetic)
Invert Emulsions	10 and 25 µ Z-Media® (synthetic), 10 µ ASP Media
Water Glycols	3, 5, 10 and 25 µ Z-Media® (synthetic) and all ASP Media (synthetic)
Phosphate Esters	All Z-Media® and ASP Media (synthetic) with H (EPR) seal designation
Skydrol®	3, 5, 10 and 25 µ Z-Media® and all ASP Media (synthetic) with H.5 seal designation (EPR seals and stainless steel wire mesh in element, and light oil coating on housing exterior)

**Fluid Compatibility**

NF30  
NFS30  
YF30  
CFX30  
PLD

Pressure	Element		Element selections are predicated on the use of 150 SUS (32 cSt) petroleum based fluid and a 40 psi (2.8 bar) bypass valve.				
	Series	Part No.					
To 6000 psi (415 bar)	E Media	CC3	CC3				
		CC10	CC10				
		CC25	CC25				
	Z- Media®	CCZ1	CCZ1	See KC65			
		CCZ3	CCZ3	See KC65			
		CCZ5	CCZ5				
		CCZ10	CCZ10				
	CCZ25	CCZ25					
Flow	gpm	0	10	20	30	40	50
	(L/min)	0	50	100	150	190	

**Element Selection Based on Flow Rate**

DF40  
CF40  
PF40  
RFS50  
RF60  
**CF60**

Shown above are the elements most commonly used in this housing.

Note: Contact factory regarding use of E Media in High Water Content, Invert Emulsion and Water Glycol Applications. For more information, refer to Fluid Compatibility: Fire Resistant Fluids, pages 19 and 20.

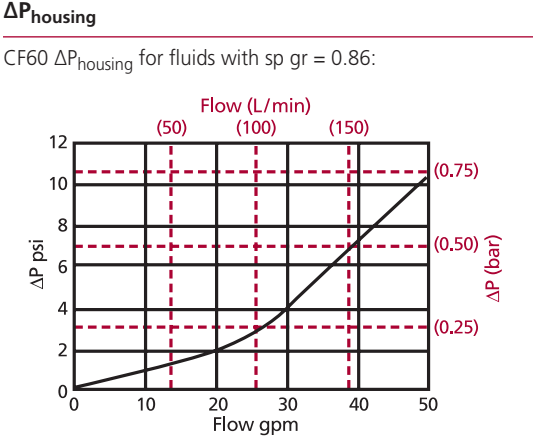

**ΔP<sub>element</sub>**

ΔP<sub>element</sub> = flow x element ΔP factor x viscosity factor

El. ΔP factors @ 150 SUS (32 cSt):

CC3	.22
CC10	.13
CC25	.03
CCZ1	.35
CCZ3/CCAS3	.20
CCZ5/CCAS5	.19
CCZ10/CCAS10	.10
CCZ25	.05
CCZX3	.29
CCZX10	.26

If working in units of bars & L/min, divide above factor by 54.9.

Viscosity factor: Divide viscosity by 150 SUS (32 cSt).

**Pressure Drop Information Based on Flow Rate and Viscosity**

KF30  
TF50  
KF50  
KC50  
MKF50  
KC65  
NOF30-05  
NOF50-760

sp gr = specific gravity

Sizing of elements should be based on element flow information provided in the Element Selection chart above.

**Notes**

---



---



---



---



---



---

**ΔP<sub>filter</sub> = ΔP<sub>housing</sub> + ΔP<sub>element</sub>**

**Exercise:**

Determine ΔP at 30 gpm (115 L/min) for CF601CCZ3SD5 using 200 SUS (44 cSt) fluid.

**Solution:**

ΔP<sub>housing</sub> = 4.0 psi [.30 bar]

ΔP<sub>element</sub> = 30 x .20 x (200÷150) = 8.0 psi  
or  
= [115 x (.20÷54.9) x (44÷32) = .58 bar]

ΔP<sub>total</sub> = 7.0 + 7.2 = 14.2 psi  
or  
= [.30 + .58 = .88 bar]

FOF60-03  
NMF30  
RMF60  
Cartridge Elements  
HS60  
MHS60  
KFH50

## How to Build a Valid Model Number for a Schroeder CF40:

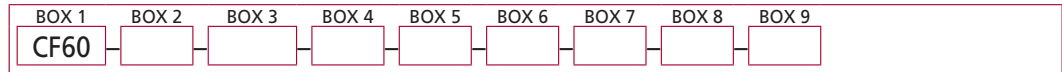

**Example:** NOTE: One option per box

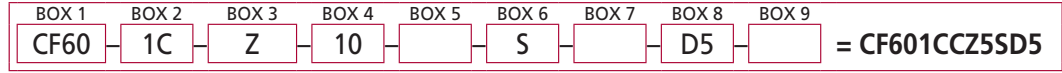

BOX 1	BOX 2		BOX 3	
Filter Series	Number and Size of Elements		Media Type	
CF60	1	CC	Omit	E Media (cellulose)
CFN60 <small>(Non-bypassing: requires ZX high collapse elements)</small>			Z	= Excellement® Z-Media® (synthetic)
			ZX	= Excellement® Z-Media® (high collapse center tube)
			AS	= Anti-Stat Media (synthetic)

BOX 4		BOX 5	BOX 6
Micron Rating		Seal Material	Porting
1	= 1 Micron (Z media)	Omit = Buna N	S = SAE-20
3	= 3 Micron (AS, E, Z and ZX media)	V = Viton®	P = 1¼" NPTF
5	= 5 Micron (AS, Z, and ZX media)	H = EPR	F = 1¼" SAE 4-bolt flange code 62
10	= 10 Micron (AS, E, Z, and ZX media)	H.5 = Skydrol® compatibility	B = ISO 228 G-1¼"
25	= 25 Micron (E, Z and ZX media)		

BOX 7	BOX 8	
Options	Dirt Alarm® Options	
Omit = None	Omit = None	
50 = 50 psi bypass setting	Visual	D5 = Visual pop-up
	Visual with Thermal Lockout	D8 = Visual w/ thermal lockout
	Electrical	MS5 = Electrical w/ 12 in. 18 gauge 4-conductor cable MS5LC = Low current MS5 MS10 = Electrical w/ DIN connector (male end only) MS10LC = Low current MS10 MS11 = Electrical w/ 12 ft. 4-conductor wire MS12 = Electrical w/ 5 pin Brad Harrison connector (male end only) MS12LC = Low current MS12 MS16 = Electrical w/ weather-packed sealed connector MS16LC = Low current MS16 MS17LC = Electrical w/ 4 pin Brad Harrison male connector
	Electrical with Thermal Lockout	MS5T = MS5 (see above) w/ thermal lockout MS5LCT = Low current MS5T MS10T = MS10 (see above) w/ thermal lockout MS10LCT = Low current MS10T MS12T = MS12 (see above) w/ thermal lockout MS12LCT = Low current MS12T MS16T = MS16 (see above) w/ thermal lockout MS16LCT = Low current MS16T MS17LCT = Low current MS17T
	Electrical Visual	MS13 = Supplied w/ threaded connector & light MS14 = Supplied w/ 5 pin Brad Harrison connector & light (male end)
	Electrical Visual with Thermal Lockout	MS13DCT = MS13 (see above), direct current, w/ thermal lockout MS13DCLCT = Low current MS13DCT MS14DCT = MS14 (see above), direct current, w/ thermal lockout MS14DCLCT = Low current MS14DCT

BOX 9
Additional Options
Omit = None
N = No-Element Indicator (CF60 only)

**NOTES:**

Box 2. Replacement element part numbers are identical to contents of Boxes 2, 3, 4 and 5. E media (cellulose) elements are only available with Buna N seals.

Box 5. H.5 seal designation includes the following: EPR seals, stainless steel wire mesh on elements, and light oil coating on housing exterior. Viton® is a registered trademark of DuPont Dow Elastomers. Skydrol® is a registered trademark of Solutia Inc.

Box 6. B porting option supplied with metric mounting holes.

Box 8. Standard indicator setting for non-bypassing model is 50 psi unless otherwise specified.

Box 9. N option should be used in conjunction with dirt alarm.