

Base-Ported Pressure Filter

KF30



Features and Benefits

- Base-ported pressure filter
- Can be installed in vertical or horizontal position
- Meets HF4 automotive standard
- Element changeout from top minimizes oil spillage
- Offered in pipe, SAE straight thread, flanged and ISO 228 porting
- No-Element indicator option available
- Available with non-bypass option with high collapse element
- Integral inlet and outlet female test points option available
- Offered in conventional subplate porting
- Same day shipment model available
- Double and triple stacking of K-size elements can be replaced by single KK or 27K-size elements

100/150 gpm
380/570 L/min
3000 psi
210 bar

NF30
 NFS30
 YF30
 CFX30
 PLD
 DF40
 CF40
 PF40
 RFS50
 RF60
 CF60
 CTF60

Model No. of filter in photograph is KF301K10SD.



INDUSTRIAL



AUTOMOTIVE
MANUFACTURING



MACHINE
TOOL



MINING
TECHNOLOGY



PULP & PAPER



AGRICULTURE



MOBILE
VEHICLES



WASTE WATER
TREATMENT

Applications

VF60
 LW60
KF30
 TF50
 KF50
 KC50
 MKF50
 KC65
 NOF30-05

Flow Rating:	Up to 100 gpm (380 L/min) for 150 SUS (32 cSt) fluids With 2" porting only, up to 150 gpm (570 L/min) for 150 SUS (32 cSt) fluids
Max. Operating Pressure:	3000 psi (210 bar)
Min. Yield Pressure:	12,000 psi (830 bar), per NFPA T2.6.1
Rated Fatigue Pressure:	2500 psi (170 bar), per NFPA T2.6.1-2005
Temp. Range:	-20°F to 225°F (-29°C to 107°C)
Bypass Setting:	Cracking: 40 psi (2.8 bar) Full Flow: 61 psi (4.2 bar) Non-bypassing model has a blocked bypass.
Porting Base & Cap: Element Case:	Ductile Iron Steel
Weight of KF30-1K:	48 lbs. (22 kg)
Weight of KF30-2K:	65 lbs. (30 kg)
Weight of KF30-3K:	81 lbs. (37 kg)
Element Change Clearance:	8.50" (215 mm) for 1K; 17.50" (445 mm) for KK; 26.5" (673 mm) for 27K

Filter Housing Specifications

NOF50-760
 FOF60-03
 NMF30
 RMF60
 Cartridge Elements
 HS60
 MHS60
 KFH50

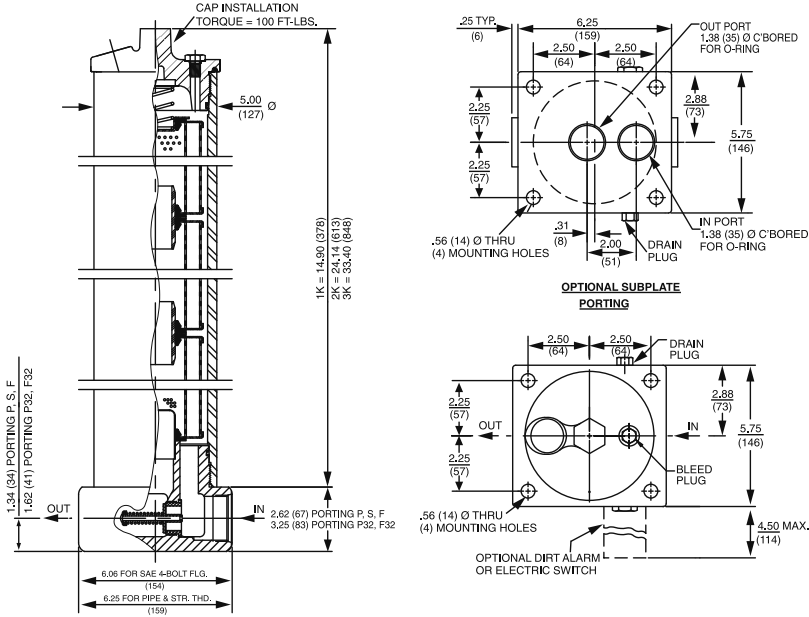

Metric dimensions in ().

Element Performance Information

Element	Filtration Ratio Per ISO 4572/NFPA T3.10.8.8 Using automated particle counter (APC) calibrated per ISO 4402			Filtration Ratio wrt ISO 16889 Using APC calibrated per ISO 11171	
	$\beta_x \geq 75$	$\beta_x \geq 100$	$\beta_x \geq 200$	$\beta_x(c) \geq 200$	$\beta_x(c) \geq 1000$
K3/KK3/27K	6.8	7.5	10.0	N/A	N/A
K10/KK10/27K10	15.5	16.2	18.0	N/A	N/A
KZ1/KKZ1/27KZ1	<1.0	<1.0	<1.0	<4.0	4.2
KZ3/KKZ3/27KZ3/KAS3/KKAS3/27KAS3	<1.0	<1.0	<2.0	<4.0	4.8
KZ5/KKZ5/27KZ5/KAS5/KKAS5/27KAS5	2.5	3.0	4.0	4.8	6.3
KZ10/KKZ10/27KZ10/KAS10/KKAS10/27KAS10	7.4	8.2	10.0	8.0	10.0
KZ25/KKZ25/27KZ25	18.0	20.0	22.5	19.0	24.0
KZW1	N/A	N/A	N/A	<4.0	<4.0
KZW3/KKZW3	N/A	N/A	N/A	4.0	4.8
KZW5/KKZW5	N/A	N/A	N/A	5.1	6.4
KZW10/KKZW10	N/A	N/A	N/A	6.9	8.6
KZW25/KKZW25	N/A	N/A	N/A	15.4	18.5
KZX3/KKZX3/27KZX3	<1.0	<1.0	<2.0	4.7	5.8
KZX10/KKZX10/27KZX10	7.4	8.2	10.0	8.0	9.8

Dirt Holding Capacity

Element	DHC (gm)	Element	DHC (gm)	Element	DHC (gm)	Element	DHC (gm)	Element	DHC (gm)
K3	54	KK3	108	27K3	162				
K10	44	KK10	88	27K10	132				
KZ1	112	KKZ1	224	27KZ1	336	KZW1	61		
KZ3/KAS3	115	KKZ3/KKAS3	230	27KZ3/27KAS3	345	KZW3	64	KKZW3	128
KZ5/KAS5	119	KKZ5/KKAS5	238	27KZ5/27KAS5	357	KZW5	63	KKZW5	126
KZ10/KAS10	108	KKZ10/KKAS10	216	27KZ10/27KAS10	324	KZW10	57	KKZW10	114
KZ25	93	KKZ25	186	27KZ25	279	KZW25	79	KKZW25	158
KZX3	40*	KKZX3	80	27KZX3	120				
KZX10	49*	KKZX10	98	27KZX10	147				

Element Collapse Rating: 150 psid (10 bar) for standard elements
3000 psid (210 bar) for high collapse (ZX) versions

Flow Direction: Outside In

Element Nominal Dimensions: K: 3.9" (99 mm) O.D. x 9.0" (230 mm) long
KK: 3.9" (99 mm) O.D. x 18.0" (460 mm) long
27K: 3.9" (99 mm) O.D. x 27.0" (690 mm) long

*Based on 100 psi terminal pressure

Base-Ported Pressure Filter

KF30

Type Fluid	Appropriate Schroeder Media
Petroleum Based Fluids	All E media (cellulose), Z-Media® and ASP Media (synthetic)
High Water Content	All Z-Media® and ASP Media (synthetic)
Invert Emulsions	10 and 25 µ Z-Media® (synthetic), 10 µ ASP Media
Water Glycols	3, 5, 10 and 25 µ Z-Media® (synthetic) and all ASP Media
Phosphate Esters	All Z-Media® and ASP Media (synthetic) with H (EPR) seal designation and 3 and 10 µ E media (cellulose) with H (EPR) seal designation
Skydrol®	3, 5, 10 and 25 µ Z-Media® (synthetic) and all ASP Media (synthetic) with H.5 seal designation and W media (water removal) with H.5 seal designation (EPR seals and stainless steel wire mesh in element, and light oil coating on housing exterior)

Fluid Compatibility	
	NF30
	NFS30
	YF30
	CFX30
	PLD
	DF40

Element Selection Based on Flow Rate	
	CF40
	PF40
	RFS50
	RF60
	CF60
	CTF60
	VF60
	LW60

Pressure	Element		Element selections are predicated on the use of 150 SUS (32 cSt) petroleum based fluid and a 40 psi (2.8 bar) bypass valve.						
	Series	Part No.							
To 3000 psi (210 bar)	E Media	K3	1K3	2K3†	3K3	See MKF50			
		K10	1K10	2K10†	3K10†	3K10†	See MKF50		
		K25	1K25			2K25†			
	Z-Media®	KZ1	1KZ1		2KZ1†		3KZ1†		
		KZ3	1KZ3/KAS3/KKAS3/27KAS3			2KZ3†		3KZ3†	
		KZ5	1KZ5/KAS5/KKAS5/27KAS5			2KZ5†		3KZ5†	
		KZ10	1KZ10/KAS10/KKAS10/27KAS10				2KZ10†		3KZ10†
		KZ25	1KZ25				2KZ25†		
	Flow	gpm	0	25	50	75	100	125	150
		(L/min)	0	100	200	300	400	500	570

†Double and triple stacking of K-size elements can be replaced by single KK & 27K elements, respectively. requires 2" porting (P32 or F32)

Shown above are the elements most commonly used in this housing.

Note: Contact factory regarding use of E Media in High Water Content, Invert Emulsion and Water Glycol Applications. For more information, refer to Fluid Compatibility: Fire Resistant Fluids, pages 19 and 20.

ΔP_{housing}

KF30 ΔP_{housing} for fluids with sp gr = 0.86:

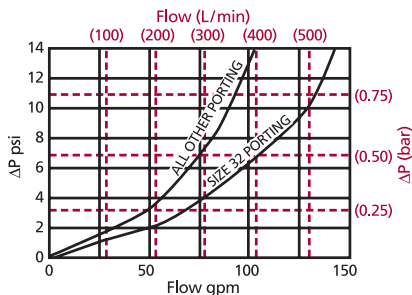

sp gr = specific gravity

Sizing of elements should be based on element flow information provided in the Element Selection chart above.

$$\Delta P_{\text{filter}} = \Delta P_{\text{housing}} + \Delta P_{\text{element}}$$

Exercise:

Determine ΔP at 75 gpm (285 L/min) for KF302K10PD using 200 SUS (44 cSt) fluid.

Solution:

$$\begin{aligned} \Delta P_{\text{housing}} &= 7.0 \text{ psi } [.50 \text{ bar}] \\ \Delta P_{\text{element}} &= 75 \times .05 \times (200 \div 150) = 5.0 \text{ psi} \\ &\text{or} \\ &= [285 \times (.05 \div 54.9) \times (44 \div 32) = .35 \text{ bar}] \\ \Delta P_{\text{total}} &= 7.0 + 5.0 = 12.0 \text{ psi} \\ &\text{or} \\ &= [.50 + .35 = .85 \text{ bar}] \end{aligned}$$

ΔP_{element}

ΔP_{element} = flow x element ΔP factor x viscosity factor

El. ΔP factors @ 150 SUS (32 cSt):

	1K	2K/KK	3K/27K
K3	.25	.12	.08
K10	.09	.05	.03
K25	.02	.01	.01
KZ1	.20	.10	.05
KZ3/KAS3/KKAS3/27KAS3	.10	.05	.03
KZ5/KAS5/KKAS5/27KAS5	.08	.04	.02
KZ10/KAS10/ KKAS10/27KAS10	.05	.03	.02
KZ25	.04	.02	.01
KZX10	.08	.04	.03

	1K	2K
KZW1	.43	
KZW3	.32	.16
KZW5	.28	.14
KZW10	.23	.12
KZW25	.14	.07

If working in units of bars & L/min, divide above factor by 54.9.

Viscosity factor: Divide viscosity by 150 SUS (32 cSt).

Pressure Drop Information Based on Flow Rate and Viscosity

KF30	TF50
	KF50
	KC50
	MKF50
	KC65
	NOF30-05
	NOF50-760
	FOF60-03
	NMF30
	RMF60
	Cartridge Elements
	HS60
	MHS60
	KFH50

Filter Model Number Selection

Same Day Shipment Model available with GeoSeal®
See inside back cover for details.

How to Build a Valid Model Number for a Schroeder KF30:

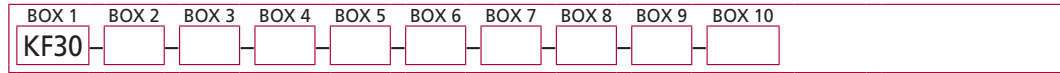

Example: NOTE: Only boxes 8 and 10 may contain more than one option

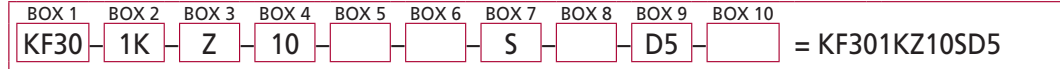

Filter Series	Number & Size of Elements	Media Type
KF30	1 K, KK, 27K	Omit = E Media (Cellulose)
KFN30 (Non-bypassing; requires ZX high collapse elements)	2 K	AS = Anti-Stat Media (synthetic)
	3 K	Z = Excellement® Z-Media® (synthetic)
		ZW = Aqua-Excellement® ZW Media
		ZX = Excellement® Z-Media® (High Collapse centertube)
		W = W Media (water removal)
		M = Media (reusable metal mesh) N size only

BOX 4 Micron Rating		BOX 5 Seal Material	BOX 6 Magnet option	BOX 7 Porting
1 = 1 Micron	(Z, ZW, ZX media)	Omit = Buna N	Omit = None	P = 1 1/2" NPTF
3 = 3 Micron	(AS, E, Z, ZW, ZX media)	V = Viton®	M = Magnet inserts (not available w/ indicator in cap)	P32 = 2" NPTF
5 = 5 Micron	(AS, Z, ZW, ZX media)	H = EPR		S = SAE-24
10 = 10 Micron	(AS, E, M, Z, ZW, ZX media)	H.5 = Skydrol® compatibility		F = 1 1/2" SAE 4-bolt flange Code 61
25 = 25 Micron	(E, Z, ZW, ZX media)			F32 = 2" SAE 4-bolt flange Code 61
60 = 60 Micron	(M media)			O = Subplate
150 = 150 Micron	(M media)			B24 = ISO 228
260 = 260 Micron	(M media)			G-1 1/2"

BOX 8 Options	BOX 9 Dirt Alarm® Options	BOX 10 Additional Options
Omit = None	Omit = None	Omit = None
X = Blocked bypass	D = Pointer	N = No-Element Indicator (not available w/ KFN30 or housings w/ indicator in cap)
50 = 50 psi bypass setting	D5 = Visual pop-up	G509 = Dirt Alarm and drain opposite standard
L = Two 1/4" NPTF inlet & outlet female test ports	D5C = D5 in cap	G588 = Electric Switch and drain opposite standard
U = Series 1215 7/16 UNF Schroeder Check Test Point installed in cap (upstream)	D9 = All stainless D5	
UU = Series 1215 7/16 UNF Schroeder Check Test Point installed in block (upstream and downstream)	D8 = Visual w/ thermal lockout	
	D8C = D8 in cap	
	MS5 = Electrical w/ 12 in. 18 gauge 4-conductor cable	
	MS5LC = Low current MS5	
	MS10 = Electrical w/ DIN connector (male end only)	
	MS10LC = Low current MS10	
	MS11 = Electrical w/ 12 ft. 4-conductor wire	
	MS12 = Electrical w/ 5 pin Brad Harrison connector (male end only)	
	MS12LC = Low current MS12	
	MS16 = Electrical w/ weather-packed sealed connector	
	MS16LC = Low current MS16	
	MS17LC = Electrical w/ 4 pin Brad Harrison male connector	
	MS5T = MS5 (see above) w/ thermal lockout	
	MS5LCT = Low current MS5T	
	MS10T = MS10 (see above) w/ thermal lockout	
	MS10LCT = Low current MS10T	
	MS12T = MS12 (see above) w/ thermal lockout	
	MS12LCT = Low current MS12T	
	MS16T = MS16 (see above) w/ thermal lockout	
	MS16LCT = Low current MS16T	
	MS17LCT = Low current MS17T	
	MS = Cam operated switch w/ 1/2" conduit female connection	
	MS13 = Supplied w/ threaded connector & light	
	MS14 = Supplied w/ 5 pin Brad Harrison connector & light (male end)	
	MS13DCT = MS13 (see above), direct current, w/ thermal lockout	
	MS13DCLCT = Low current MS13DCT	
	MS14DCT = MS14 (see above), direct current, w/ thermal lockout	
	MS14DCLCT = Low current MS14DCT	

NOTES:

- Box 2. Number of elements must equal 1 when using KK or 27K elements. Replacement element part numbers are identical to contents of Boxes 2, 3, 4 and 5. Double and triple stacking of K-size elements can be replaced by single KK and 27K elements, respectively. ZW media not available in 27K length.
- Box 5. H.5 seal designation includes the following: EPR seals, stainless steel wire mesh on elements, and light oil coating on housing exterior. Viton® is a registered trademark of DuPont Dow Elastomers. Skydrol® is a registered trademark of Solutia Inc.
- Box 7. For options F & F32, bolt depth .75" (19 mm).
For option O, O-rings included; hardware not included.
- Box 8. X and 50 options are not available with KFN30.
- Box 9. Standard indicator setting for non-bypassing model is 50 psi unless otherwise specified.
- Box 10. Options N, G509 and G588 are not available with KFN30. N option should be used in conjunction with dirt alarm.