

Return Line Filter With 2" Ports

LF1



Features and Benefits

- Offered in pipe, SAE straight thread and ISO 228 porting
- Available in 18" element lengths only
- Various Dirt Alarm® options
- Available with NPTF inlet and outlet female test ports
- Available with 2" porting with "K" size element
- Available with housing drain plug
- WLF1 model for water service also available – refer to Section 7 of this catalog

120 gpm
455 L/min
300 psi
20 bar

IRF
TF1
KF3
KL3
LF1-2"

MLF1
RLD
GRTB
MTA
MTB
ZT

Model No. of filter in photograph is LF118LCZ10P32D.



INDUSTRIAL



AUTOMOTIVE
MANUFACTURING



MACHINE
TOOL



MOBILE
VEHICLES

Applications

KFT
RT
RTI
LRT
ART
BFT
QT
KTK
LTK

MRT

Filter Housing Specifications

Accessories
for Tank-
Mounted
Filters

PAF1

MAF1

MF2

Flow Rating:	Up to 120 gpm (455 L/min) for 150 SUS (32 cSt) fluids
Max. Operating Pressure:	300 psi (20 bar)
Min. Yield Pressure:	1000 psi (70 bar), per NFPA T2.6.1
Rated Fatigue Pressure:	250 psi (17 bar), per NFPA T2.6.1-2005
Temp. Range:	-20°F to 225°F (-29°C to 107°C)
Bypass Setting:	Cracking: 30 psi (2.1 bar) Full Flow: 60 psi (4.1 bar)
Porting Head:	Cast Aluminum
Element Case:	Steel
Available Porting:	2" NPTF, 2½-12 SAE Straight
Weight of LF1-18LC:	17.5 lbs. (7.9 kg)
Element Change Clearance:	2.0" (55 mm)

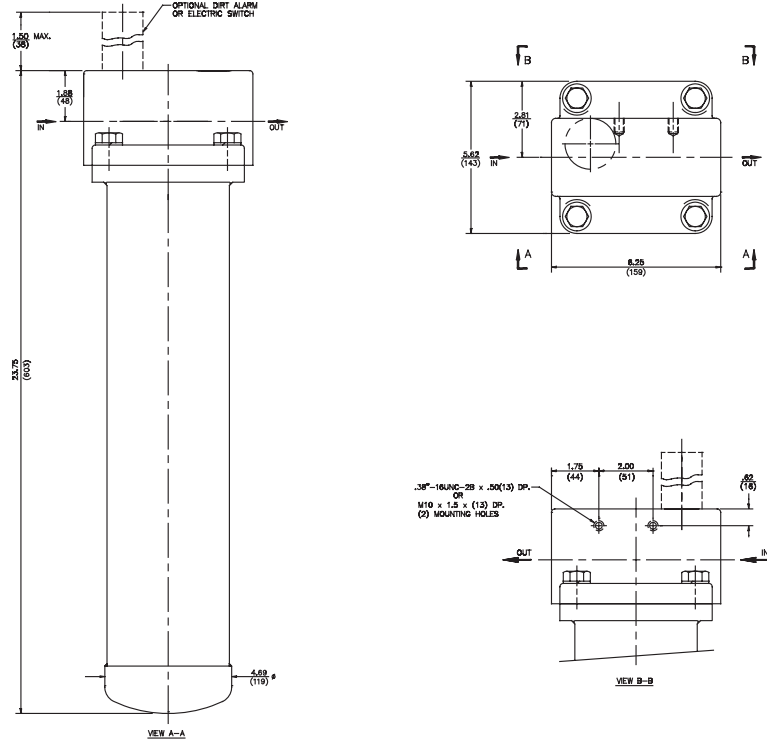

Metric dimensions in ().

Element Performance Information

Element	Filtration Ratio Per ISO 4572/NFPA T3.10.8.8 Using automated particle counter (APC) calibrated per ISO 4402			Filtration Ratio wrt ISO 16889 Using APC calibrated per ISO 11171	
	$\beta_x \geq 75$	$\beta_x \geq 100$	$\beta_x \geq 200$	$\beta_x(c) \geq 200$	$\beta_x(c) \geq 1000$
18LC3	6.8	7.5	10.0	N/A	N/A
18LC10	15.5	16.2	18.0	N/A	N/A
18LCZ1	<1.0	<1.0	<1.0	<4.0	4.2
18LCZ3	<1.0	<1.0	<2.0	<4.0	4.8
18LCZ5	2.5	3.0	4.0	4.8	6.3
18LCZ10	7.4	8.2	10.0	8.0	10.0
18LCZ25	18.0	20.0	22.5	19.0	24.0

Dirt Holding Capacity

Element	DHC (gm)
18LC3	110
18LC10	88
18LCZ1	200
18LCZ3	205
18LCZ5	228
18LCZ10	203
18LCZ25	184

Element Collapse Rating: 150 psid (10 bar)

Flow Direction: Outside In

Element Nominal Dimensions: 4.0" (100 mm) O.D. x 18.5" (470 mm) long

Return Line Filter With 2" Ports

LF1

Type Fluid	Appropriate Schroeder Media
Petroleum Based Fluids	All E media (cellulose) and Z-Media® (synthetic)
High Water Content	All Z-Media (synthetic)
Invert Emulsions	10 and 25 µ Z-Media® (synthetic)
Water Glycols	3, 5, 10 and 25 µ Z-Media® (synthetic)
Phosphate Esters	All Z-Media® (synthetic) with H (EPR) seal designation
Skydrol®	3, 5, 10 and 25 µ Z-Media® (synthetic) with H.5 seal designation (EPR seals and stainless steel wire mesh in element, and light oil coating on housing exterior)

Fluid Compatibility

IRF
TF1
KF3
KL3

Skydrol® is a registered trademark of Solutia Inc.

LF1-2"

Pressure	Element		Element selections are predicated on the use of 150 SUS (32 cSt) petroleum based fluid and a 30 psi (2.1 bar) bypass valve.			
	Series	Part No.				
To 300 psi (20 bar)	Z-Media®	18LCZ1	18LCZ1			
		18LCZ3	18LCZ3			
		18LCZ5	18LCZ5			
		18LCZ10	18LCZ10			
		18LCZ25	18LCZ25			
Flow	gpm	0	60	80	100	120
	(L/min)	0	230	300	380	455

Element Selection Based on Flow Rate

MLF1
RLD
GRTB
MTA
MTB
ZT

Shown above are the elements most commonly used in this housing.

Note: Contact factory regarding use of E media in High Water Content, Invert Emulsion and Water Glycol Applications. For more information, refer to Fluid Compatibility: Fire Resistant Fluids, pages 19 and 20.

ΔP_{housing}

LF1-2" ΔP_{housing} for fluids with sp gr = 0.86:

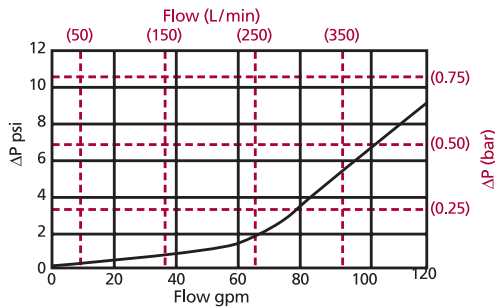

sp gr = specific gravity

Sizing of elements should be based on element flow information provided in the Element Selection chart above.

ΔP_{element}

ΔP_{element} = flow x element ΔP factor x viscosity factor

El. ΔP factors @ 150 SUS (32 cSt):

18LCZ1	.10
18LCZ3	.05
18LCZ5	.04
18LCZ10	.03
18LCZ25	.02

If working in units of bars & L/min, divide above factor by 54.9.

Viscosity factor: Divide viscosity by 150 SUS (32 cSt).

Pressure Drop Information Based on Flow Rate and Viscosity

RT
RTI
LRT
ART
BFT
QT
KTK
LTK
MRT

Notes

$$\Delta P_{\text{filter}} = \Delta P_{\text{housing}} + \Delta P_{\text{element}}$$

Exercise:

Determine ΔP at 40 gpm (150 L/min) for LF118LCZ10S32D5 using 200 SUS (44 cSt) fluid.

Solution:

$$\begin{aligned} \Delta P_{\text{housing}} &= 1.0 \text{ psi } [.07 \text{ bar}] \\ \Delta P_{\text{element}} &= 40 \times .03 \times (200 \div 150) = 1.6 \text{ psi} \\ &\text{or} \\ &= [150 \times (.03 \div 54.9) \times (44 \div 32)] = .11 \text{ bar} \\ \Delta P_{\text{total}} &= 1.0 + 1.6 = 2.6 \text{ psi} \\ &\text{or} \\ &= [.07 + .11] = .18 \text{ bar} \end{aligned}$$

Accessories for Tank-Mounted Filters

PAF1
MAF1
MF2

Filter Model Number Selection

How to Build a Valid Model Number for a Schroeder LF1:

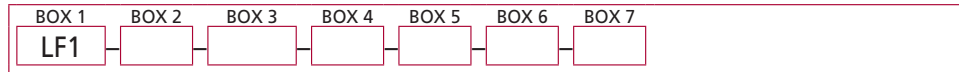

Example: NOTE: Only box 7 may contain more than one option

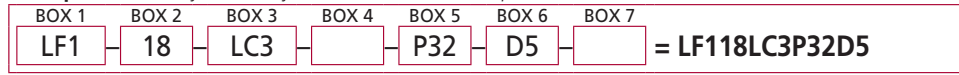

BOX 1	BOX 2	BOX 3	BOX 4
Filter Series	Length of Element (in)	Element Size and Media	Seal Material
LF1	18	LC3 = LC size 3 μ E media (cellulose) LC10 = LC size 10 μ E media (cellulose) LCZ1 = LC size 1 μ Excellement® Z-Media™ (synthetic) LCZ3 = LC size 3 μ Excellement Z-Media (synthetic) LCZ5 = LC size 5 μ Excellement Z-Media (synthetic) LCZ10 = LC size 10 μ Excellement Z-Media (synthetic) LCZ25 = LC size 25 μ Excellement Z-Media (synthetic)	Omit = Buna N H = EPR V = Viton® H.5 = Skydrol® Compatibility

BOX 5	BOX 6	BOX 7
Porting	Dirt Alarm® Options	Additional Options
P32 = 2" NPTF	Omit = None	Omit = None
S32 = SAE-32	Visual	L = Two ¼" NPTF inlet and outlet female test ports
B32 = ISO 228 G-2"	D5 = Visual pop-up	G426 = ¾" drain on bottom of housing
	D8 = Visual w/ thermal lockout	G440 = ½" drain on bottom of housing
	Electrical	
	MS5 = Electrical w/ 12 in. 18 gauge 4-conductor cable	
	MS5LC = Low current MS5	
	MS10 = Electrical w/ DIN connector (male end only)	
	MS10LC = Low current MS10	
	MS11 = Electrical w/ 12 ft. 4-conductor wire	
	MS12 = Electrical w/ 5 pin Brad Harrison connector (male end only)	
	MS12LC = Low current MS12	
	MS16 = Electrical w/ weather-packed sealed connector	
	MS16LC = Low current MS16	
	MS17LC = Electrical w/ 4 pin Brad Harrison male connector	
	Electrical with Thermal Lockout	
	MS5T = MS5 (see above) w/ thermal lockout	
	MS5LCT = Low current MS5T	
	MS10T = MS10 (see above) w/ thermal lockout	
	MS10LCT = Low current MS10T	
	MS12T = MS12 (see above) w/ thermal lockout	
	MS12LCT = Low current MS12T	
	MS16T = MS16 (see above) w/ thermal lockout	
	MS16LCT = Low current MS16T	
	MS17LCT = Low current MS17T	
	Electrical Visual	
	MS = Cam operated switch w/ ½" conduit female connection	
	MS13 = Supplied w/ threaded connector & light	
	MS14 = Supplied w/ 5 pin Brad Harrison connector & light (male end)	
	Electrical Visual with Thermal Lockout	
	MS13DCT = MS13 (see above), direct current, w/ thermal lockout	
	MS13DCLCT = Low current MS13DCT	
	MS14DCT = MS14 (see above), direct current, w/ thermal lockout	
	MS14DCLCT = Low current MS14DCT	

NOTES:

Box 2. Replacement element part numbers are a combination of Boxes 2, 3, and 4. Example: 18LCZ3V

Box 4. For options H, V, and H.5, all aluminum parts are anodized. H.5 seal designation includes the following: EPR seals, stainless steel wire mesh on elements, and light oil coating on housing exterior. Viton® is a registered trademark of DuPont Dow Elastomers. Skydrol® is a registered trademark of Solutia Inc.

Box 5. B porting option supplied with metric mounting holes.