

SAME DAY SHIPMENT MODEL AVAILABLE!

Tank-Mounted Filter

LRT



Features and Benefits

- Low pressure tank-mounted filter
- Multiple inlet/outlet porting options
- Top, side or bottom mounting
- Optional check valve prevents reservoir siphoning
- Can also be used in return line application (contact factory)
- Visual gauge or electrical switch dirt alarms
- Offered in pipe, SAE straight thread, flanged and ISO 228 porting
- Same day shipment model available
- Also available with DirtCatcher® elements (18LD)

150 gpm
570 L/min

100 psi
7 bar

IRF
 TF1
 KF3
 KL3
 LF1-2"
 MLF1
 RLD
 GRTB
 MTA
 MTB
 ZT

Model No. of filter in photograph is LRT18LZ10S24NP16Y2.



INDUSTRIAL



MOBILE VEHICLES



RAILROAD



STEEL MAKING



CONSTRUCTION



AGRICULTURE

Applications

KFT
 RT
 RTI
LRT
 ART
 BFT
 QT
 KTK
 LTK
 MRT

Flow Rating:	Up to 150 gpm (570 L/min) for 150 SUS (32 cSt) fluids
Max. Operating Pressure:	100 psi (7 bar)
Min. Yield Pressure:	400 psi (28 bar), per NFPA T2.6.1
Rated Fatigue Pressure:	90 psi (6 bar), per NFPA T2.6.1-2005
Temp. Range:	-20°F to 225°F (-29°C to 107°C)
Bypass Setting:	Cracking: 25 psi (1.7 bar) Full Flow: 34 psi (2.3 bar)
Porting Head & Cap:	Die Cast Aluminum
Element Case:	Steel
Weight of LRT-18L:	14.6 lbs. (6.6 kg)
Element Change Clearance:	17.0" (432 mm)

Filter Housing Specifications

Accessories for Tank-Mounted Filters

PAF1
 MAF1
 MF2

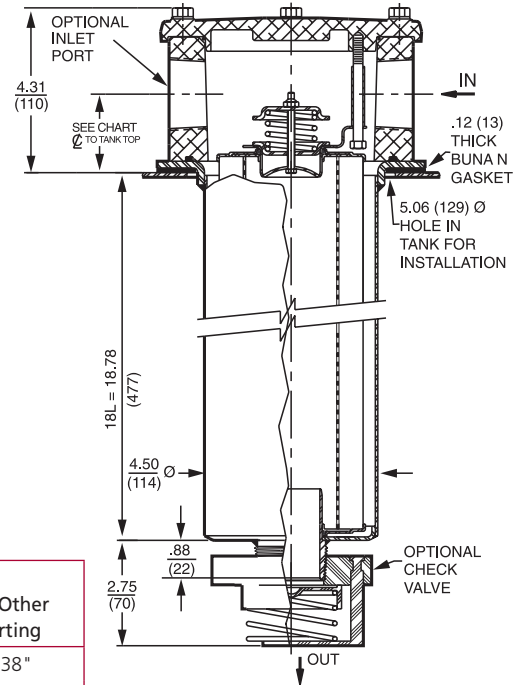
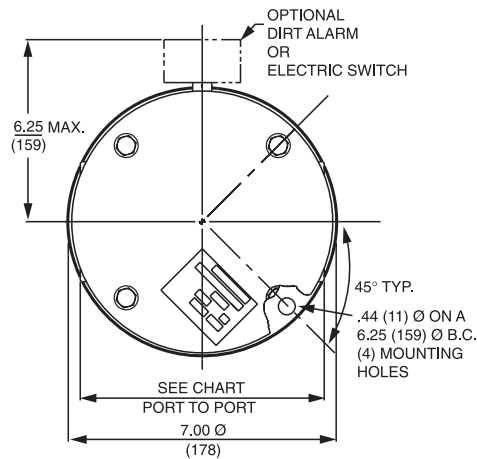

	1½" Ports 4-Bolt Flange Only	2" Ports	All Other Porting
Port to Port	7.12"	7.56" (P, S, B) 7.38" (F)	6.38"
℄ to Casting Base	1.75"	1.81"	1.56"
℄ to Tank Top	2.06"	2.12"	1.88"

Optional mounting ring available to weld to tank.

Metric dimensions in ().

Element Performance Information

Element	Filtration Ratio Per ISO 4572/NFPA T3.10.8.8 Using automated particle counter (APC) calibrated per ISO 4402			Filtration Ratio wrt ISO 16889 Using APC calibrated per ISO 11171	
	$\beta_x \geq 75$	$\beta_x \geq 100$	$\beta_x \geq 200$	$\beta_x(c) \geq 200$	$\beta_x(c) \geq 1000$
18L3	6.8	7.5	10.0	N/A	N/A
18L10	15.5	16.2	18.0	N/A	N/A
18LZ1	<1.0	<1.0	<1.0	<4.0	4.2
18LZ3	<1.0	<1.0	<2.0	<4.0	4.8
18LZ5	2.5	3.0	4.0	4.8	6.3
18LZ10	7.4	8.2	10.0	8.0	10.0
18LZ25	18.0	20.0	22.5	19.0	24.0

Dirt Holding Capacity

Element	DHC (gm)	Element	DHC (gm)
18L3	110		
18L10	88		
18LZ1	249	18LDZ1	194
18LZ3	255	18LDZ3	199
18LZ5	191	18LDZ5	149
18LZ10	240	18LDZ10	186
18LZ25	217	18LDZ25	169

Element Collapse Rating: 150 psid (10 bar)

Flow Direction: Outside In

Element Nominal Dimensions: 4.0" (100 mm) O.D. x 18.5" (470 mm) long

SAME DAY SHIPMENT MODEL AVAILABLE!

Tank-Mounted Filter

LRT

Type Fluid	Appropriate Schroeder Media
Petroleum Based Fluids	All E media (cellulose) and Z-Media® (synthetic)
High Water Content	All Z-Media® (synthetic)
Invert Emulsions	10 and 25 µ Z-Media® (synthetic)
Water Glycols	3, 5, 10 and 25 µ Z-Media® (synthetic)
Phosphate Esters	All Z-Media® (synthetic) with H (EPR) seal designation
Skydrol®	3, 5, 10 and 25 µ Z-Media® (synthetic) with H.5 seal designation (EPR seals and stainless steel wire mesh in element, and light oil coating on housing exterior)

Fluid Compatibility

IRF
TF1
KF3
KL3
LF1-2"

Skydrol® is a registered trademark of Solutia Inc.

Pressure	Element		Element selections are predicated on the use of 150 SUS (32 cSt) petroleum based fluid and a 25 psi (1.7 bar) bypass valve.						
	Series	Part No.	18LZ1		18LZ3		See BFT		
Return Line -Tank-Mounted	Z-Media®	18LZ1	18LZ1		18LZ3		See BFT		
		18LZ3	18LZ3		18LZ5		See BFT		
		18LZ5	18LZ5		18LZ10		See BFT		
		18LZ10	18LZ10		18LZ25		See BFT		
		18LZ25	18LZ25						
Flow	gpm		0	25	50	75	100	125	150
	(L/min)		0	100	200	300	400	500	570

Element Selection Based on Flow Rate

MLF1
RLD
GRTB
MTA
MTB
ZT

Shown above are the elements most commonly used in this housing.

Note: Contact factory regarding use of E media in High Water Content, Invert Emulsion and Water Glycol Applications. For more information, refer to Fluid Compatibility: Fire Resistant Fluids, pages 19 and 20.

ΔP_{housing}

LRT ΔP_{housing} for fluids with sp gr = 0.86:

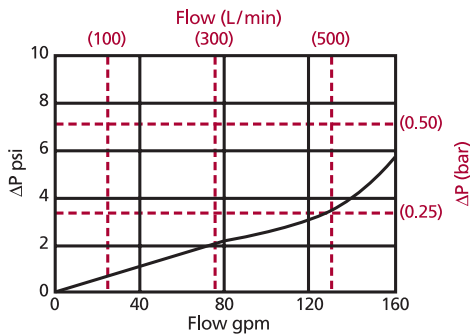

sp gr = specific gravity

Sizing of elements should be based on element flow information provided in the Element Selection chart above.

ΔP_{element}

ΔP_{element} = flow x element ΔP factor x viscosity factor

El. ΔP factors @ 150 SUS (32 cSt):

	18L		18L
18LZ1	.10	18LDZ1	.12
18LZ3	.05	18LDZ3	.06
18LZ5	.04	18LDZ5	.05
18LZ10	.03	18LDZ10	.03
18LZ25	.02	18LDZ25	.02

If working in units of bars & L/min, divide above factor by 54.9.

Viscosity factor: Divide viscosity by 150 SUS (32 cSt).

Pressure Drop Information Based on Flow Rate and Viscosity

KFT
RT
RTI
LRT
ART
BFT
QT
KTK
LTK
MRT

Notes

$$\Delta P_{\text{filter}} = \Delta P_{\text{housing}} + \Delta P_{\text{element}}$$

Exercise:

Determine ΔP at 120 gpm (455 L/min) for LRT18LZ5P24Y2 using 200 SUS (44 cSt) fluid.

Solution:

$$\begin{aligned} \Delta P_{\text{housing}} &= 3.0 \text{ psi } [.20 \text{ bar}] \\ \Delta P_{\text{element}} &= 120 \times .04 \times (200 \div 150) = 6.4 \text{ psi} \\ &\text{or} \\ &= [455 \times (.04 \div 54.9) \times (44 \div 32)] = .45 \text{ bar} \\ \Delta P_{\text{total}} &= 3.0 + 6.4 = 9.4 \text{ psi} \\ &\text{or} \\ &= [.20 + .45] = .65 \text{ bar} \end{aligned}$$

Accessories for Tank-Mounted Filters
PAF1
MAF1
MF2

Filter Model Number Selection

Same Day Shipment Model
See inside back cover for details.

How to Build a Valid Model Number for a Schroeder LRT:

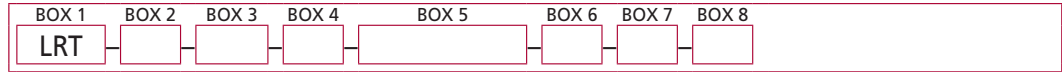

Example: NOTE: Only box 8 may contain more than one option



BOX 1	BOX 2	BOX 3	BOX 4
Filter Series	Element Length (in)	Element Size and Media	Seal Material
LRT	18	L3 = L size 3 μ E media (cellulose) L10 = L size 10 μ E media (cellulose) LZ1 = L size 1 μ Excellement® Z-Media® (synthetic) LZ3 = L size 3 μ Excellement® Z-Media® (synthetic) LZ5 = L size 5 μ Excellement® Z-Media® (synthetic) LZ10 = L size 10 μ Excellement® Z-Media® (synthetic) LZ25 = L size 25 μ Excellement® Z-Media® (synthetic) LDZ1 = L size DirtCatcher® 1 μ Excellement® Z-Media® LDZ3 = L size DirtCatcher® 3 μ Excellement® Z-Media® LDZ5 = L size DirtCatcher® 5 μ Excellement® Z-Media® LDZ10 = L size DirtCatcher® 10 μ Excellement® Z-Media® LDZ25 = L size DirtCatcher® 25 μ Excellement® Z-Media®	Omit = Buna N H = EPR W = Buna N H.5 = Skydrol® compatibility

BOX 5 Specification of all 3 ports is required			BOX 6
Inlet Porting			Outlet Porting Options
Port A	Port B	Port C	
P16 = 1" NPTF	N = None P16 = 1" NPTF	N = None P2 = 1/8" NPTF	Omit = 2" NPT male
P20 = 1 1/4" NPTF	P20 = 1 1/4" NPTF	P16 = 1" NPTF	C = Check valve
P24 = 1 1/2" NPTF	P24 = 1 1/2" NPTF	S16 = SAE-16	D = Diffuser
P32 = 2" NPTF	P32 = 2" NPTF		T = 13" Tube extension
S16 = SAE-16	S16 = SAE-16		A = Non-threaded outlet
S20 = SAE-20	S20 = SAE-20		
S24 = SAE-24	S24 = SAE-24		
S32 = SAE-32	S32 = SAE-32		
F20 = 1 1/4" SAE 4-bolt flange Code 61	F20 = 1 1/4" SAE 4-bolt flange Code 61		
F24 = 1 1/2" SAE 4-bolt flange Code 61	F24 = 1 1/2" SAE 4-bolt flange Code 61		
F32 = 2" SAE 4-bolt flange Code 61	F32 = 2" SAE 4-bolt flange Code 61		
B24 = ISO 228 G-1 1/2"	B24 = ISO 228 G-1 1/2"		
		Inlet Porting Location	

BOX 7		BOX 8
Dirt Alarm® Options		Additional Options
	Omit = None	Omit = None
Located @ Port D	Visual	Y2 = Back-mounted tri-color gauge
	Electrical	ES = Electric switch ES1 = Heavy-duty electric switch with conduit connector
Located in cap	Visual	Y2C = Bottom-mounted tri-color gauge Y5 = Back-mounted gauge in cap
	Visual	Y2R = Back-mounted gauge mounted on opposite side of standard location
Located @ Port C	Visual	ESR = Electric switch mounted on opposite side of standard location
	Electrical	ES1R = Heavy-duty electric switch with conduit connector
		G2293 = Cork gasket G547 = Two 1/8" gauge ports G820 = Stamped cap M = Metric thread for SAE 4-bolt flange mounting holes (specify after each F port designation)

NOTES:

- Box 2. Replacement element part numbers are a combination of Boxes 2, 3, and 4. Example: 18LZ10
- Box 4. For options H, W, and H.5, all aluminum parts are anodized. H.5 seal designation includes the following: EPR seals, stainless steel wire mesh on elements, and light oil coating on housing exterior. Skydrol® is a registered trademark of Solutia Inc.
- Box 5. If using Port B, Port A & B must always be the same type and size. Example: (A) P20 (B) P20 (C) P16
- Box 6. See also "Accessories for Tank-Mounted Filters," page 295.