

Spin-On Filter **MAF1**



Features and Benefits

- Spin-On with full ported die cast aluminum head for minimal pressure drop
- Offered in pipe, SAE straight thread and ISO 228 porting
- Spin-On thread = 1.50-16UN-2B
- Visual gauge or electrical switch dirt alarms
- Small profile for use in limited space
- Available in 7" and 10" element lengths
- Available with NPTF inlet and outlet female test ports

50 gpm
190 L/min
100 psi
7 bar

IRF
 TF1
 KF3
 KL3
 LF1-2"
 MLF1
 RLD
 GRTB
 MTA
 MTB
 ZT

Model No. of filter in photograph is MAF17M10S.



INDUSTRIAL



MOBILE VEHICLES



AUTOMOTIVE MANUFACTURING



MACHINE TOOL



STEEL MAKING



AGRICULTURE



PULP & PAPER

Applications

KFT
 RT
 RTI
 LRT
 ART
 BFT
 QT
 KTK
 LTK
 MRT

Flow Rating:	Up to 50 gpm (190 L/min) for 150 SUS (32 cSt) fluids
Max. Operating Pressure:	100 psi (7 bar)
Min. Yield Pressure:	150 psi (10 bar), per NFPA T2.6.1
Rated Fatigue Pressure:	Contact factory
Temp. Range:	-20°F to 225°F (-29°C to 107°C)
Bypass Setting:	Cracking: 30 psi (2 bar) Full Flow: 48 psi (3 bar)
Porting Head & Cap:	Die Cast Aluminum
Element Case:	Steel
Weight of MAF1-7M:	4.2 lbs. (1.9 kg)
Weight of MAF1-10M:	5.0 lbs. (2.3 kg)
Element Change Clearance:	2.50" (65 mm)

Filter Housing Specifications

Accessories for Tank-Mounted Filters

PAF1
MAF1
 MF2

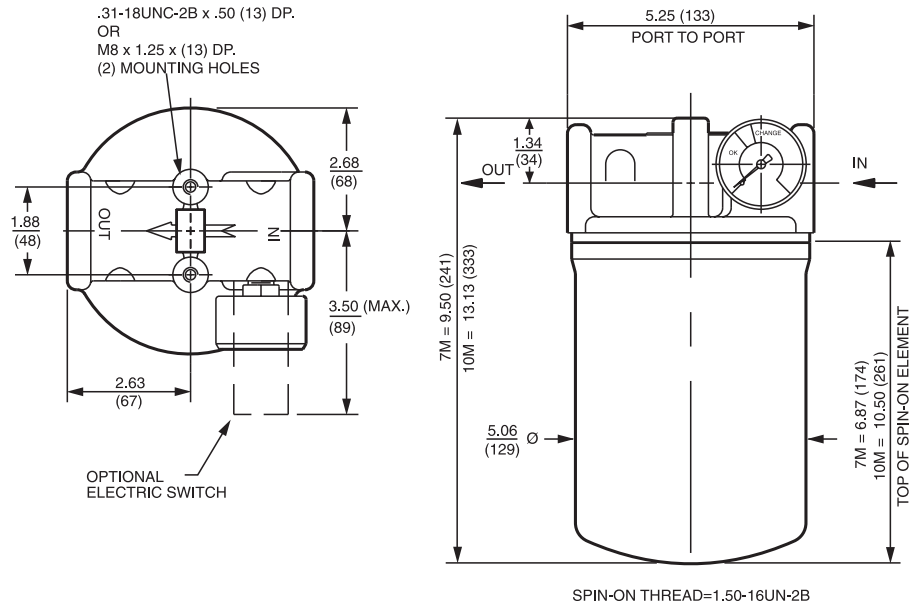

Installation instructions included on element.

Metric dimensions in ().

Element Performance Information

Element	Filtration Ratio Per ISO 4572/NFPA T3.10.8.8 Using automated particle counter (APC) calibrated per ISO 4402			Filtration Ratio wrt ISO 16889 Using APC calibrated per ISO 11171	
	$\beta_x \geq 75$	$\beta_x \geq 100$	$\beta_x \geq 200$	$\beta_x(c) \geq 200$	$\beta_x(c) \geq 1000$
7M3	6.8	7.5	10.0	N/A	N/A
7M10	15.5	16.2	18.0	N/A	N/A
7MZ3/10MZ3	<1.0	<1.0	<2.0	<4.0	4.8
7MZ10/10MZ10	7.4	8.2	10.0	8.0	10.0
10MZW10	N/A	N/A	N/A	6.9	8.6

Dirt Holding Capacity

Element	DHC (gm)	Element	DHC (gm)
7M3	50	10MZW10	53
7M10	37		
7MZ3	105		
7MZ10	104		

Element Collapse Rating: 100 psid (7 bar)

Flow Direction: Outside In

Element Nominal Dimensions: 7M: 5.0" (125 mm) O.D. x 7.0" (180 mm) long
10M: 5.0" (125 mm) O.D. x 10.5" (261 mm) long

Type Fluid	Appropriate Schroeder Media
Petroleum Based Fluids	All E media (cellulose) and Z-Media® (synthetic)
High Water Content	3 and 10 μ Z-Media® (synthetic)
Invert Emulsions	10 μ Z-Media® (synthetic)
Water Glycols	3 and 10 μ Z-Media® (synthetic)

Fluid Compatibility

IRF
TF1
KF3
KL3
LF1-2"

Pressure	Element		Element selections are predicated on the use of 150 SUS (32 cSt) petroleum based fluid and a 30 psi (2.1 bar) bypass valve.				
	Series	Part No.					
To 100 psi (7 bar)	E Media	M3	M3		See RLT		
		M10	M10		See RLT		
	Z- Media®	MZ3	MZ3		See RLT		
		MZ10	MZ10		See RLT		
Flow	gpm	0	10	20	30	40	50
	(L/min)	0	50	100	150	190	

Element Selection Based on Flow Rate

MLF1
RLD
GRTB
MTA
MTB
ZT

Shown above are the elements most commonly used in this housing.

Note: Contact factory regarding use of E media in High Water Content, Invert Emulsion and Water Glycol Applications. For more information, refer to Fluid Compatibility: Fire Resistant Fluids, pages 19 and 20.

ΔP_{housing}

MAF1 ΔP_{housing} for fluids with sp gr = 0.86:

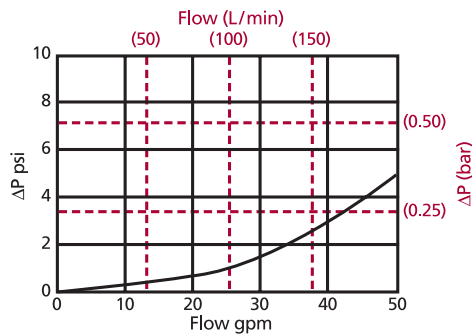

sp gr = specific gravity

Sizing of elements should be based on element flow information provided in the Element Selection chart above.

ΔP_{element}

ΔP_{element} = flow x element ΔP factor x viscosity factor

El. ΔP factors @ 150 SUS (32 cSt):

7M3	.23
7M10	.14
7MZ3	.22
7MZ10	.17

If working in units of bars & L/min, divide above factor by 54.9.

Viscosity factor: Divide viscosity by 150 SUS (32 cSt).

Pressure Drop Information Based on Flow Rate and Viscosity

KFT
RT
RTI
LRT
ART
BFT
QT
KTK
LTK
MRT

Notes

$$\Delta P_{\text{filter}} = \Delta P_{\text{housing}} + \Delta P_{\text{element}}$$

Exercise:

Determine ΔP at 25 gpm (95 L/min) for MAF17M3P using 200 SUS (44 cSt) fluid.

Solution:

$$\begin{aligned} \Delta P_{\text{housing}} &= 1.0 \text{ psi } [.08 \text{ bar}] \\ \Delta P_{\text{element}} &= 25 \times .23 \times (200 \div 150) = 7.7 \text{ psi} \\ &\text{or} \\ &= [95 \times (.23 \div 54.9) \times (44 \div 32)] = .54 \text{ bar} \\ \Delta P_{\text{total}} &= 1.0 + 7.7 = 8.7 \text{ psi} \\ &\text{or} \\ &= [.08 + .54 = .62 \text{ bar}] \end{aligned}$$

Accessories for Tank-Mounted Filters

PAF1

MAF1

MF2

Filter Model Number Selection

How to Build a Valid Model Number for a Schroeder MAF1:

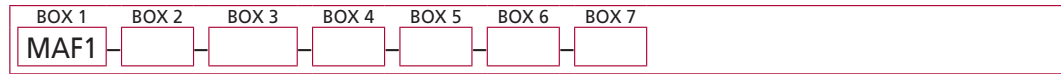

Example: NOTE: One option per box

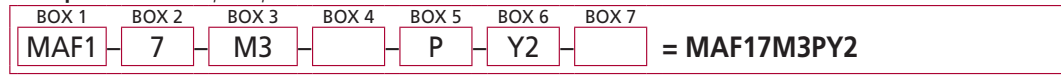

BOX 1	BOX 2	BOX 3	BOX 4
Filter Series	Element Length (in)	Element Size and Media	Seal Material
MAF1	7 10	M3 = M size 3 μ E media (cellulose) M10 = M size 10 μ E media (cellulose) MZ3 = M size 3 μ Excellement® Z-Media® (synthetic) MZ10 = M size 10 μ Excellement® Z-Media® (synthetic) MZW10 = M size 10 μ Aqua-Excellement™ ZW media MW = M size W media (water removal)	Omit = None V = Viton®

BOX 5	BOX 6	BOX 7						
Porting Options	Dirt Alarm® Options	Additional Options						
P = 1¼" NPTF S = SAE-20 B = ISO 228 G-1¼"	<table border="1"> <tr> <td></td> <td>Omit = None</td> </tr> <tr> <td>Visual</td> <td>Y2 = Back-mounted tri-color gauge</td> </tr> <tr> <td>Electrical</td> <td>ES = Electric switch</td> </tr> </table>		Omit = None	Visual	Y2 = Back-mounted tri-color gauge	Electrical	ES = Electric switch	Omit = None L = Two ½" NPTF inlet and outlet female test ports
	Omit = None							
Visual	Y2 = Back-mounted tri-color gauge							
Electrical	ES = Electric switch							

NOTES:

- Box 2. Replacement element part numbers are a combination of Boxes 2, 3, and 4. Replacement element part numbers for 7" length begin with M. Replacement element part numbers for 10" length begin with 10M. Examples: M3V; 10MZ3V 10" only available with MZ3 and MZ10.
- Box 3. ZW media only available for 10" element.
- Box 4. For option V, all aluminum parts are anodized. Viton® is a registered trademark of DuPont Dow Elastomers.
- Box 5. B porting option supplied with metric mounting holes.