

Medium Pressure In-Tank Filter

MRT



Features and Benefits

- Medium pressure tank mounted filter ideal for applications with high pressure surge in the return line
- Two possible inlet porting locations
- Various Dirt Alarm® options available
- Also available with DirtCatcher® element
- Option sampling available upon request

150 gpm
570 L/min
900 psi
62 bar

IRF
 TF1
 KF3
 KL3
 LF1-2"
 MLF1
 RLD
 GRTB
 MTA
 MTB
 ZT

Model No. of filter in photograph is MRT18LZ10S24S24D5.



INDUSTRIAL



MOBILE
VEHICLES



STEEL
MAKING



AGRICULTURE

Applications

KFT
 RT
 RTI
 LRT
 ART
 BFT
 QT
 KTK
 LTK

MRT

Flow Rating:	Up to 150 gpm (570 L/min) for 150 SUS (32 cSt) fluids
Max. Operating Pressure:	900 psi (62 bar)
Min. Yield Pressure:	2700 psi (186 bar), per NFPA T2.6.1
Rated Fatigue Pressure:	750 psi (52 bar), per NFPA T2.6.1-2005
Temp. Range:	-20°F to 225°F (-29°C to 107°C)
Bypass Setting:	Cracking: 40 psi (2.8 bar)
Porting Head & Cap:	Cast Aluminum (Anodized)
Element Case:	Steel
Weight of MRT:	36.0 lbs. (16.4 kg)
Element Change Clearance:	17.0" (432 mm)

Filter Housing Specifications

Accessories for Tank-Mounted Filters

PAF1
 MAF1
 MF2

Medium Pressure In-Tank Filter

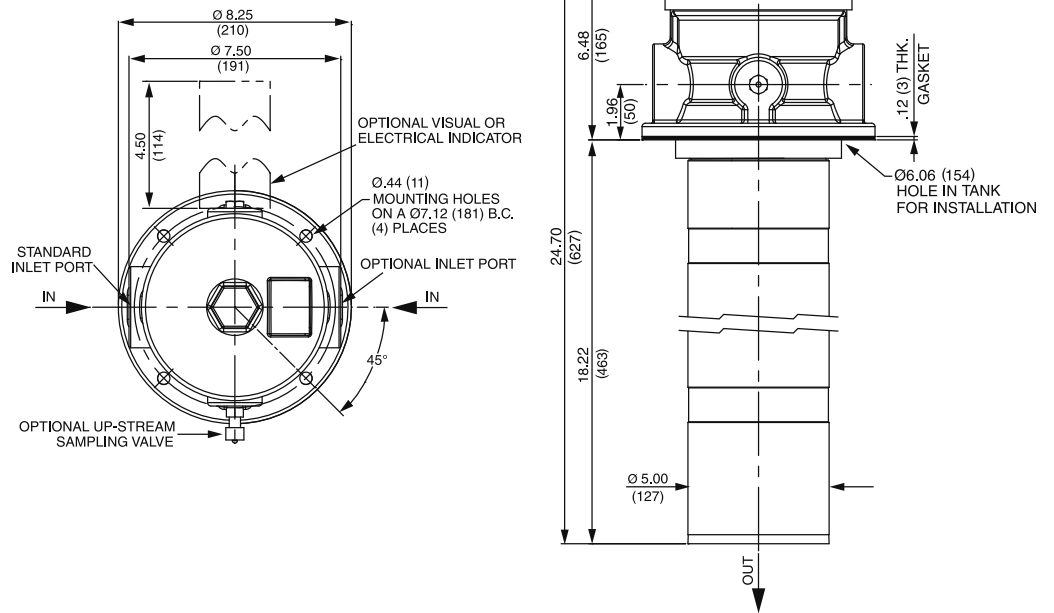

Metric dimensions in ().

Element Performance Information

Element	Filtration Ratio Per ISO 4572/NFPA T3.10.8.8 Using automated particle counter (APC) calibrated per ISO 4402			Filtration Ratio wrt ISO 16889 Using APC calibrated per ISO 11171	
	$\beta_x \geq 75$	$\beta_x \geq 100$	$\beta_x \geq 200$	$\beta_x(c) \geq 200$	$\beta_x(c) \geq 1000$
18L3	6.8	7.5	10.0	N/A	N/A
18LZ1	<1.0	<1.0	<1.0	<4.0	4.2
18LZ3	<1.0	<1.0	<2.0	<4.7	5.8
18LZ5	2.5	3.0	4.0	6.5	7.5
18LZ10	7.4	8.2	10.0	10.0	12.7
18LZ25	18.0	20.0	22.5	19.0	24.0
18LDZ1	<1.0	<1.0	<1.0	<4.0	4.2
18LDZ3	<1.0	<1.0	<2.0	<4.7	5.8
18LDZ5	2.5	3.0	4.0	6.5	7.5
18LDZ10	7.4	8.2	10.0	10.0	12.7
18LDZ25	18.0	20.0	22.5	19.0	24.0

Dirt Holding Capacity

Element	DHC (gm)	Element	DHC (gm)
18L3	110	18LDZ1	194
18LZ1	249	18LDZ3	199
18LZ3	255	18LDZ5	149
18LZ5	191	18LDZ10	186
18LZ10	240	18LDZ25	169
18LZ25	217		

Element Collapse Rating: 150 psid (10 bar)

Flow Direction: Outside In

Element Nominal Dimensions: 4.0" (100 mm) O.D. x 18.5" (470 mm) long

Medium Pressure In-Tank Filter



Type Fluid	Appropriate Schroeder Media
Petroleum Based Fluids	All E media (cellulose) and Z-Media® (synthetic)
High Water Content	All Z-Media® (synthetic)
Invert Emulsions	10 and 25 µ Z-Media® (synthetic)
Water Glycols	3, 5, 10 and 25 µ Z-Media® (synthetic)

Fluid Compatibility

IRF
TF1
KF3
KL3

Pressure	Element		Element selections are predicated on the use of 150 SUS (32 cSt) petroleum based fluid and a 40 psi (2.8 bar) bypass valve.					
	Series	Part No.						
Return Line Tank-Mounted	Z-Media®	18LZ1/18LDZ1	18LDZ1		18LZ1			
		18LZ3/18LDZ3	18LZ3/18LDZ3					
		18LZ5/18LDZ5	18LZ5/18LDZ5					
		18LZ10/18LDZ10	18LZ10/18LDZ10					
		18LZ25/18LDZ25	18LZ25/18LDZ25					
Flow	gpm	0	25	50	75	100	125	150
	(L/min)	0	100	200	300	400		570

Element Selection Based on Flow Rate

LF1-2"
MLF1
RLD
GRTB
MTA
MTB
ZT

Shown above are the elements most commonly used in this housing.

Note: Contact factory regarding use of E media in High Water Content, Invert Emulsion and Water Glycol Applications. For more information, refer to Fluid Compatibility: Fire Resistant Fluids, pages 19 and 20.

ΔP_{housing}

MRT ΔP_{housing} for fluids with sp gr = 0.86:

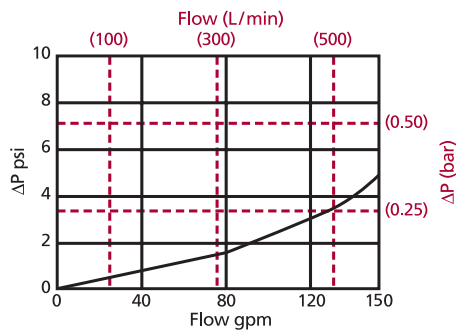

sp gr = specific gravity

Sizing of elements should be based on element flow information provided in the Element Selection chart above.

ΔP_{element}

ΔP_{element} = flow x element ΔP factor x viscosity factor

El. ΔP factors @ 150 SUS (32 cSt):

	18L		18LD
18LZ1	.10	18LDZ1	.12
18LZ3	.05	18LDZ3	.06
18LZ5	.04	18LDZ5	.05
18LZ10	.03	18LDZ10	.03
18LZ25	.02	18LDZ25	.02

If working in units of bars & L/min, divide above factor by 54.9.

Viscosity factor: Divide viscosity by 150 SUS (32 cSt).

Pressure Drop Information Based on Flow Rate and Viscosity

KFT
RT
RTI
LRT
ART
BFT
QT
KTK
LTK

Notes

$$\Delta P_{\text{filter}} = \Delta P_{\text{housing}} + \Delta P_{\text{element}}$$

Exercise:

Determine ΔP at 120 gpm (455 L/min) for MRT18LZ5S24S24D5 using 200 SUS (44 cSt) fluid.

Solution:

$$\begin{aligned} \Delta P_{\text{housing}} &= 3.0 \text{ psi } [.21 \text{ bar}] \\ \Delta P_{\text{element}} &= 120 \times .04 \times (200 \div 150) = 6.4 \text{ psi} \\ &\text{or} \\ &= [455 \times (.02 \div 54.9) \times (44 \div 32) = .23 \text{ bar}] \\ \Delta P_{\text{total}} &= 3.0 + 6.4 = 9.4 \text{ psi} \\ &\text{or} \\ &= [.21 + .23 = .44 \text{ bar}] \end{aligned}$$



Accessories for Tank-Mounted Filters

PAF1
MAF1
MF2

Filter Model Number Selection

How to Build a Valid Model Number for a Schroeder MRT:

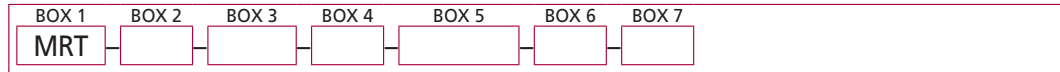

Example: NOTE: One option per box



BOX 1	BOX 2	BOX 3	BOX 4
Filter Series	Element Length (in)	Element Size and Media	Seal Material
MRT	18	L3 = L size 3 μ E media (cellulose) L10 = L size 10 μ E media (cellulose) LZ1 = L size 1 μ Excellement® Z-Media® (synthetic) LZ3 = L size 3 μ Excellement® Z-Media® (synthetic) LZ5 = L size 5 μ Excellement® Z-Media® (synthetic) LZ10 = L size 10 μ Excellement® Z-Media® (synthetic) LZ25 = L size 25 μ Excellement® Z-Media® (synthetic) LDZ1 = L size DirtCatcher® 1 μ Excellement® Z-Media® LDZ3 = L size DirtCatcher® 3 μ Excellement® Z-Media® LDZ5 = L size DirtCatcher® 5 μ Excellement® Z-Media® LDZ10 = L size DirtCatcher® 10 μ Excellement® Z-Media® LDZ25 = L size DirtCatcher® 25 μ Excellement® Z-Media®	Omit = Buna N

BOX 5
Specification of both ports is required

Inlet Porting		Inlet Porting Location
Port A	Port B	
S = S24 N = None	S = S24 N = None	<p style="text-align: center;">Sampling Valve (Optional)</p>

BOX 6

Dirt Alarm® Options	
	Omit = None
Visual	D5 = Visual pop-up
Visual with Thermal Lockout	D8 = Visual w/ thermal lockout
Electrical	MS5 = Electrical w/ 12 in. 18 gauge 4-conductor cable
	MS5LC = Low current MS5
	MS10 = Electrical w/ DIN connector (male end only)
	MS10LC = Low current MS10
	MS11 = Electrical w/ 12 ft. 4-conductor wire
	MS12 = Electrical w/ 5 pin Brad Harrison connector (male end only)
	MS12LC = Low current MS12
Electrical with Thermal Lockout	MS16 = Electrical w/ weather-packed sealed connector
	MS16LC = Low current MS16
	MS17LC = Electrical w/ 4 pin Brad Harrison male connector
	MS5T = MS5 (see above) w/ thermal lockout
	MS5LCT = Low current MS5T
	MS10T = MS10 (see above) w/ thermal lockout
	MS10LCT = Low current MS10T
Electrical Visual	MS12T = MS12 (see above) w/ thermal lockout
	MS12LCT = Low current MS12T
	MS16T = MS16 (see above) w/ thermal lockout
	MS16LCT = Low current MS16T
	MS17LCT = Low current MS17T
	MS13 = Supplied w/ threaded connector & light
	MS14 = Supplied w/ 5 pin Brad Harrison connector & light (male end)
Electrical Visual with Thermal Lockout	MS13DCT = MS13 (see above), direct current, w/ thermal lockout
	MS13DCLCT = Low current MS13DCT
	MS14DCT = MS14 (see above), direct current, w/ thermal lockout
	MS14DCLCT = Low current MS14DCT

BOX 7

Options
Omit = No sampling valve
SV = Up stream sampling valve

NOTES:

Box 2. Replacement element part numbers are a combination of Boxes 2, 3, and 4. Example: 18L3