

# Medium Pressure Filter

**RLD**



## Features and Benefits

- Lightweight duplex filter constructed of aluminum
- High chromium content aluminum alloy is water tolerant – anodization is not required for high water-based fluids (HWBF)
- Filter housings are designed to withstand pressure surges as well as high static pressure loads
- Screw-in bowl allows the filter element to be easily removed for replacement or cleaning
- Standard model supplied with upstream and downstream pressure ports and drain plugs
- Standard Viton® seal on filter housing
- Filter contains an integrated equalization valve
- Pressure is equalized between filters by raising the change-over lever prior to switching it to the relevant filter side

Model No. of filter in photograph is RLD25DNZ6S24DW.



INDUSTRIAL



AUTOMOTIVE  
MANUFACTURING



MACHINE  
TOOL



STEEL  
MAKING



PULP & PAPER



POWER  
GENERATION

100 gpm  
**380 L/min**  
350 psi  
**24 bar**

IRF  
TF1  
KF3  
KL3  
LF1-2"  
MLF1  
**RLD**  
GRTB  
MTA  
MTB  
ZT

## Applications

KFT  
RT  
RTI  
LRT  
ART  
BFT  
QT  
KTK  
LTK

**Filter Housing Specifications** Accessories for Tank-Mounted Filters  
MRT

Flow Rating:	Up to 100 gpm (380 L/min) for 150 SUS (32 cSt) fluids
Max. Operating Pressure:	350 psi (24 bar)
Min. Yield Pressure:	Contact factory
Rated Fatigue Pressure:	350 psi (24 bar)
Temp. Range:	-22°F to 250°F (-30°C to 121°C)
Bypass Setting:	Standard: 102 psi (7 bar) Optional: 43 psi (3.0 bar)
Porting Head:	Aluminum
Element Case:	Aluminum
Weight of RLD-25DN:	26 lbs. (11.8 kg)
Weight of RLD-40DN:	29 lbs. (13.0 kg)
Element Change Clearance:	25DN: 3.5" (89 mm) 40DN: 3.5" (89 mm)

PAF1  
MAF1  
MF2

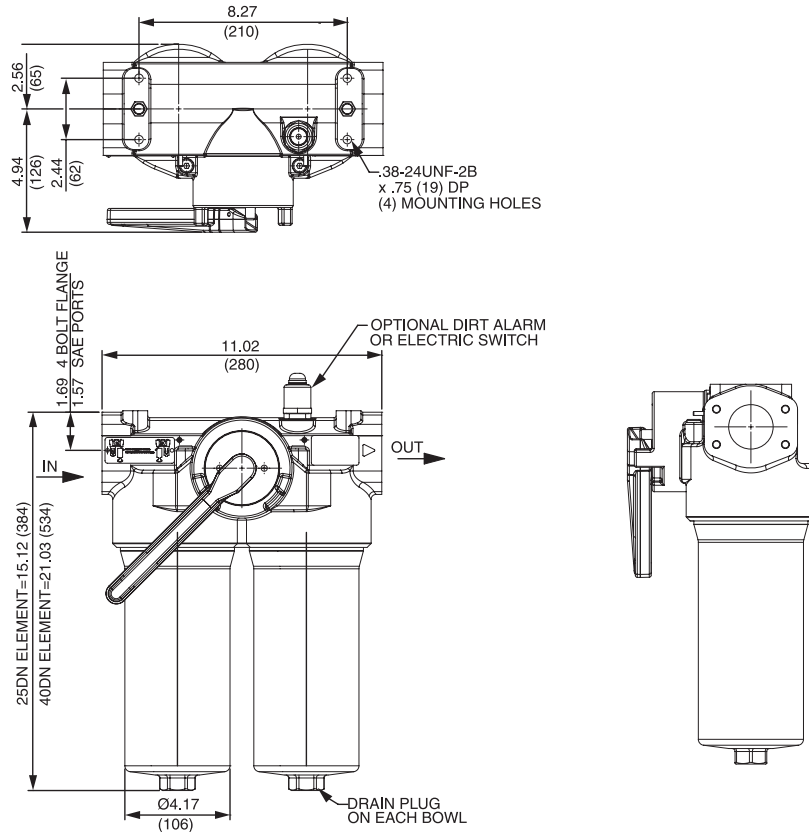

Metric dimensions in ( ).

### Element Performance Information

Element	Filtration Ratio Per ISO 4572/NFPA T3.10.8.8 Using automated particle counter (APC) calibrated per ISO 4402			Filtration Ratio wrt ISO 16889 Using APC calibrated per ISO 11171	
	$\beta_x \geq 75$	$\beta_x \geq 100$	$\beta_x \geq 200$	$\beta_x(c) \geq 200$	$\beta_x(c) \geq 1000$
25/40DNZ3	<1.0	<1.0	<2.0	<4.0	4.8
25/40DNZ6	2.5	3.0	4.0	4.8	6.3
25/40DNZ10	7.4	8.2	10.0	8.0	10.0
25/40DNZ25	18.0	20.0	22.5	19.0	24.0

### Dirt Holding Capacity

Element	DHC (gm)	Element	DHC (gm)
25DNZ3	57	40DNZ3	105
25DNZ6	62	40DNZ6	115
25DNZ10	52	40DNZ10	104
25DNZ25	48	40DNZ25	94

Element Collapse Rating: 290 psid (20 bar)  
 Flow Direction: Outside In  
 Element Nominal Dimensions: 3.0" (75 mm) O.D. x 14.5" (370 mm) long

# Medium Pressure Filter

# RLD

Type Fluid	Appropriate Schroeder Media
Petroleum Based Fluids	All Z-Media® (synthetic)
High Water Content	All Z-Media® (synthetic)
Invert Emulsions	10 and 25 µ Z-Media® (synthetic)
Water Glycols	3, 6, 10 and 25 µ Z-Media® (synthetic)

## Fluid Compatibility

IRF  
TF1  
KF3  
KL3  
LF1-2"

Pressure	Element		Element selections are predicated on the use of 150 SUS (32 cSt) petroleum based fluid and a 102 psi (7 bar) bypass valve.				
	Series	Part No.					
To 350 psi (24 bar)	Z- Media®	25DNZ3 & 40DNZ3	25DNZ3	40DNZ3			
		25DNZ6 & 40DNZ6	25DNZ6		40DNZ6		
		25DNZ10 & 40DNZ10	25DNZ10			40DNZ10	
		25DNZ25 & 40DNZ25	25DNZ25			40DNZ25	
Flow	gpm	0	20	40	60	80	100
	(L/min)	0	50	100	150	250	380

## Element Selection Based on Flow Rate

MLF1  
**RLD**  
GRTB  
MTA  
MTB

Shown above are the elements most commonly used in this housing.

### $\Delta P_{\text{housing}}$

RLD  $\Delta P_{\text{housing}}$  for fluids with sp gr = 0.86:

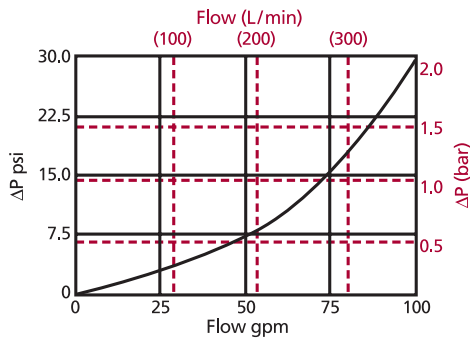

sp gr = specific gravity

Sizing of elements should be based on element flow information provided in the Element Selection chart above.

### $\Delta P_{\text{element}}$

$\Delta P_{\text{element}} = \text{flow} \times \text{element } \Delta P \text{ factor} \times \text{viscosity factor}$

El.  $\Delta P$  factors @ 150 SUS (32 cSt):

<b>25DNZ3</b>	.28	<b>40DNZ3</b>	.18
<b>25DNZ6</b>	.18	<b>40DNZ6</b>	.11
<b>25DNZ10</b>	.12	<b>40DNZ10</b>	.07
<b>25DNZ25</b>	.09	<b>40DNZ25</b>	.06

If working in units of bars & L/min, divide above factor by 54.9.

Viscosity factor: Divide viscosity by 150 SUS (32 cSt).

## Pressure Drop Information Based on Flow Rate and Viscosity

RT  
RTI  
LRT  
ART  
BFT  
QT  
KTK  
LTK  
MRT

### Notes

$$\Delta P_{\text{filter}} = \Delta P_{\text{housing}} + \Delta P_{\text{element}}$$

#### Exercise:

Determine  $\Delta P$  at 40 gpm (150 L/min) for 40DNZ6 using 200 SUS (44 cSt) fluid.

#### Solution:

$$\begin{aligned} \Delta P_{\text{housing}} &= 5.0 \text{ psi } [.34 \text{ bar}] \\ \Delta P_{\text{element}} &= 40 \times .11 \times (200 \div 150) = 5.9 \text{ psi} \\ &\text{or} \\ &= [150 \times (.11 \div 54.9) \times (44 \div 32)] = .40 \text{ bar} \\ \Delta P_{\text{total}} &= 5.0 + 5.9 = 10.9 \text{ psi} \\ &\text{or} \\ &= [.34 + .40 = .73 \text{ bar}] \end{aligned}$$

Accessories  
for Tank-  
Mounted  
Filters

PAF1  
MAF1  
MF2

## Filter Model Number Selection

### How to Build a Valid Model Number for a Schroeder RLD:

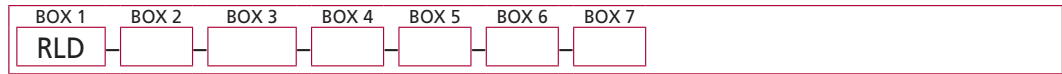

Example: NOTE: One option per box

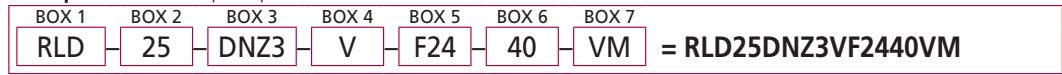

BOX 1	BOX 2	BOX 3	BOX 4
<b>Filter Series</b>	<b>Length of Elements (cm)</b>	<b>Element Size and Media</b>	<b>Element Seal Material</b>
RLD	25 40	DNZ3 = DN size 3 μ synthetic media DNZ10 = DN size 10 μ synthetic media DNZ25 = DN size 25 μ synthetic media DNM25 = DN size 25 μ M media (reusable metal) DNM50 = DN size 50 μ M media (reusable metal) DNM100 = DN size 100 μ M media (reusable metal) DNM200 = DN size 200 μ M media (reusable metal)	Omit = Buna N V = Viton®

BOX 5	BOX 6	BOX 7
<b>Porting</b>	<b>Bypass Setting</b>	<b>Dirt Alarm® Options</b>
F24 = 1½" SAE 4-bolt flange Code 61 S24 = SAE-24 (1½")	Omit = 102 psi cracking 40 = 43 psi cracking	Omit = None Visual VM = Visual pop-up w/manual reset Electrical DW = AC/DC 3-wire (NO or NC)



VM = Manual Reset

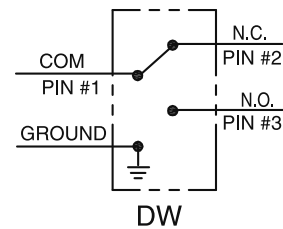

DW = AC/DC 3-wire (NO or NC)

#### NOTES:

Box 2. Replacement element part numbers are a combination of Boxes 2, 3 and 4. Example: 40DNZ10

Box 4. Filter housings are supplied with standard Viton seals. Seal designation in Box 4 applies to element only. Viton® is a registered trademark of DuPont Dow Elastomers.