

Tank-Mounted Filter (Inside Out Flow)

RTI



Features and Benefits

- Tank-mounted "Inside Out" flow filter
- Up to 3 inlet ports available
- Offered in pipe, SAE straight thread and flanged porting
- Various Dirt Alarm® options

120 gpm
455 L/min
100 psi
7 bar

IRF
TF1
KF3
KL3
LF1-2"
MLF1
RLD
GRTB
MTA
MTB
ZT

Model No. of filter in photograph is RTI3KZ10S24NP16Y2.



INDUSTRIAL



AUTOMOTIVE
MANUFACTURING



MOBILE
VEHICLES



RAILROAD



STEEL
MAKING



MACHINE
TOOL



AGRICULTURE

Applications

KFT
RT
RTI
LRT
ART
BFT
QT
KTK
LTK

Flow Rating:	Up to 120 gpm (455 L/min) for 150 SUS (32 cSt) fluids
Max. Operating Pressure:	100 psi (7 bar)
Min. Yield Pressure:	400 psi (28 bar), per NFPA T2.6.1
Rated Fatigue Pressure:	Contact factory
Temp. Range:	-20°F to 225°F (-29°C to 107°C)
Bypass Setting:	Cracking: 25 psi (2 bar) Full Flow: 62 psi (4.3 bar)
Porting Head & Cap:	Die Cast Aluminum
Element Case:	Steel
Weight of RTI-KI:	11.4 lbs. (5.2 kg)
Weight of RTI-KKI:	14.5 lbs. (6.6 kg)
Element Change Clearance:	KI Element = 9.0 (229 mm) KKI Element = 18.0 (457 mm) 27KI Element = 27.0 (686 mm)

Filter Housing Specifications

Accessories
for Tank-
Mounted
Filters
PAF1
MAF1
MF2

Tank-Mounted Filter (Inside Out Flow)

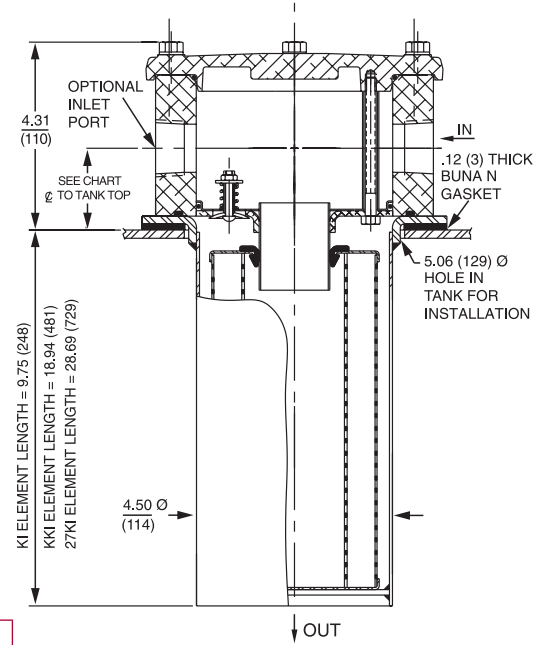
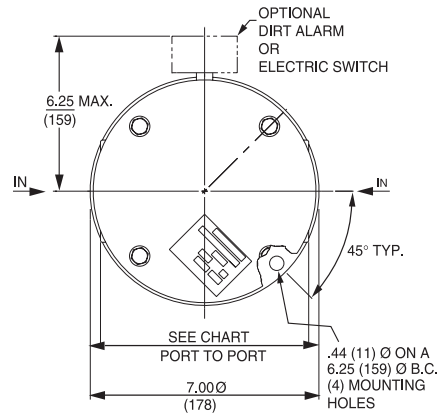

	1/4", 1/2" Standard Ports	1/2" Ports 4-Bolt Flange Only
Port to Port	6.38"	7.12"
☐ to Casting Base	1.56"	1.75"
☐ to Tank Top	1.88"	2.06"

Optional mounting rings available for tank welding. See page 295, reference part numbers A-LFT-813 and A-LFT-1448.

Metric dimensions in ().

Element Performance Information

Element	Filtration Ratio Per ISO 4572/NFPA T3.10.8.8 Using automated particle counter (APC) calibrated per ISO 4402			Filtration Ratio wrt ISO 16889 Using APC calibrated per ISO 11171	
	$\beta_x \geq 75$	$\beta_x \geq 100$	$\beta_x \geq 200$	$\beta_x(c) \geq 200$	$\beta_x(c) \geq 1000$
KIZ1	<1.0	<1.0	<1.0	<4.0	4.2
KIZ3/KIAS3	<1.0	<1.0	<2.0	<4.0	4.8
KIZ10/KIAS10	<7.4	<8.2	<10.0	8.0	10.0

Dirt Holding Capacity

Element	DHC (gm)	Element	DHC (gm)	Element	DHC (gm)
KIZ1	85	KKIZ1	181	27KIZ1	276
KIZ3/KIAS3	88	KKIZ3/KKIAS3	185	27KIZ3/27KIAS3	283
KIZ10/KIAS10	<82	KKIZ10/KKIAS10	174	27KIZ10/27KIAS10	266

Element Collapse Rating: 100 psid (7 bar)

Flow Direction: Inside Out

Element Nominal Dimensions: KI: 3.9" (99 mm) O.D. x 9.0" (230 mm) long
 KK: 3.9" (99 mm) O.D. x 18.0" (460 mm) long
 27KI: 3.9" (99 mm) O.D. x 27.0" (690 mm) long

Tank-Mounted Filter (Inside Out Flow)

RTI

Type Fluid	Appropriate Schroeder Media
Petroleum Based Fluids	All E media (cellulose), Z-Media® and ASP media (synthetic)
High Water Content	All Z-Media® and ASP media (synthetic)
Invert Emulsions	10 and 25 µ Z-Media® and 10 µ ASP media (synthetic)
Water Glycols	3, 5, 10 and 25 µ Z-Media® and all ASP media (synthetic)
Phosphate Esters	All Z-Media® (synthetic) with H (EPR) seal designation and all ASP media (synthetic)
Skydrol®	3, 5, 10 and 25 µ Z-Media® (synthetic) with H.5 seal designation (EPR seals and stainless steel wire mesh in element, and light oil coating on housing exterior) and all ASP media (synthetic)

Fluid Compatibility

IRF
TF1
KF3
KL3
LF1-2"
MLF1

Skydrol is a registered trademark of Solutia Inc.

Pressure	Element		Element selections are predicated on the use of 150 SUS (32 cSt) petroleum based fluid and a 25 psi (1.7 bar) bypass valve.			
	Series	Part No.				
Return Line -Tank-Mounted	Z-Media®	Z10	KI	KKI	27KI	
Flow	gpm	0		90	105	120
	(L/min)	0		340	400	455

Element Selection Based on Flow Rate

RLD
GRTB
MTA
MTB
ZT
KFT

Shown above are the elements most commonly used in this housing.

Note: Contact factory regarding use of E media in High Water Content, Invert Emulsion and Water Glycol Applications. For more information, refer to Fluid Compatibility: Fire Resistant Fluids, pages 19 and 20.

ΔP_{housing}

RT ΔP_{housing} for fluids with sp gr = 0.86:

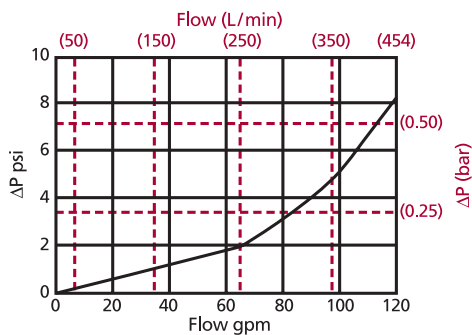

sp gr = specific gravity

Sizing of elements should be based on element flow information provided in the Element Selection chart above.

ΔP_{element}

ΔP_{element} = flow x element ΔP factor x viscosity factor

El. ΔP factors @ 150 SUS (32 cSt):

KIZ10/KIAS10	.08
KKIZ10/KKIAS10	.05
27KIZ10/27KIAS10	.04

If working in units of bars & L/min, divide above factor by 54.9.

Viscosity factor: Divide viscosity by 150 SUS (32 cSt).

Pressure Drop Information Based on Flow Rate and Viscosity

RT
RTI
LRT
ART
BFT
QT
KTK
LTK
MRT

Notes

$$\Delta P_{\text{filter}} = \Delta P_{\text{housing}} + \Delta P_{\text{element}}$$

Exercise:

Determine ΔP at 80 gpm (300 L/min) for RTIKIZ10P24NN using 200 SUS (44 cSt) fluid.

Solution:

$$\begin{aligned} \Delta P_{\text{housing}} &= 3.0 \text{ psi } [.20 \text{ bar}] \\ \Delta P_{\text{element}} &= 80 \times .05 \times (200 \div 150) = 5.3 \text{ psi} \\ &\text{or} \\ &= [300 \times (.05 \div 54.9) \times (44 \div 32) = .38 \text{ bar}] \\ \Delta P_{\text{total}} &= 3.0 + 5.3 = 8.3 \text{ psi} \\ &\text{or} \\ &= [.20 + .38 = .58 \text{ bar}] \end{aligned}$$

Accessories for Tank-Mounted Filters
PAF1
MAF1
MF2

Filter Model Number Selection

How to Build a Valid Model Number for a Schroeder RTI:

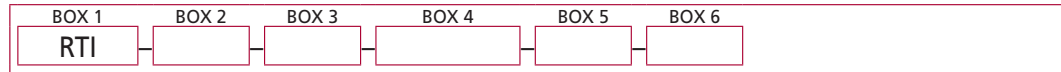

Example: NOTE: Only box 6 may contain more than one option

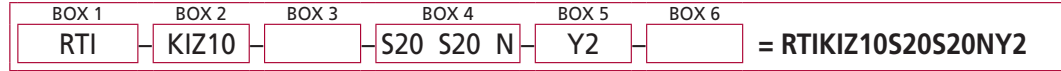

Filter Series	Element Part Number			
RTI	K Length	KK Length	27K Length	
	KIZ1	KKIZ1	27KIZ1	= 1 µ Excellement® Z-Media® and ASP media (synthetic)
	KIZ3	KKIZ3	27KIZ3	= 3 µ Excellement® Z-Media® and ASP media (synthetic)
	KIZ10	KKIZ10	27KIZ10	= 10 µ Excellement® Z-Media® and ASP media (synthetic)

BOX 3

Seal Material
Omit = Buna N
H = EPR
W = Buna N
H.5 = Skydrol® Compatibility

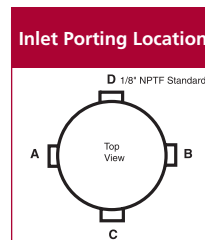

BOX 4 Specification of all 3 ports is required

Inlet Porting		
Port A	Port B	Port C
P16 = 1" NPTF	N = None	N = None
P20 = 1¼" NPTF	P16 = 1" NPTF	P2 = ⅛" NPTF
P24 = 1½" NPTF	P20 = 1¼" NPTF	P16 = 1" NPTF
S16 = SAE-16	P24 = 1½" NPTF	S16 = SAE-16
S20 = SAE-20	S16 = SAE-16	
S24 = SAE-24	S20 = SAE-20	
F20 = 1¼" SAE 4-bolt flange Code 61	S24 = SAE-24	
F24 = 1½" SAE 4-bolt flange Code 61	F20 = 1¼" SAE 4-bolt flange Code 61	
	F24 = 1½" SAE 4-bolt flange Code 61	

BOX 5 Dirt Alarm® Options			BOX 6 Additional Options
		Omit = None	Omit = None
Located @ Port D	Visual	Y2 = Back-mounted tri-color gauge	G547 = Two ⅛" gauge ports M = Metric thread for SAE 4-bolt flange mounting holes (specify after each port designation)
	Electrical	ES = Electric switch ES1 = Heavy-duty electric switch with conduit connector	
Located in cap	Visual	Y2C = Bottom-mounted tri-color gauge Y5 = Back-mounted gauge in cap	
	Visual	Y2R = Back-mounted gauge mounted on opposite side of standard location	
Located @ Port C	Visual	ESR = Electric switch mounted on opposite side of standard location	
	Electrical	ES1R = Heavy-duty electric switch with conduit connector	

NOTES:

Box 2. Replacement element part numbers are identical to contents of Boxes 2 and 3.

Box 3. For options H, W, and H.5, all aluminum parts are anodized. H.5 seal designation includes the following: EPR seals, stainless steel wire mesh on elements, and light oil coating on housing exterior. Skydrol® is a registered trademark of Solutia Inc.

Box 4. If using Port B, Port A & B must always be the same type and size. Example: (A) P20 (B) P20 (C) P16

Box 6. See also "Accessories for Tank-Mounted Filters," page 295.